

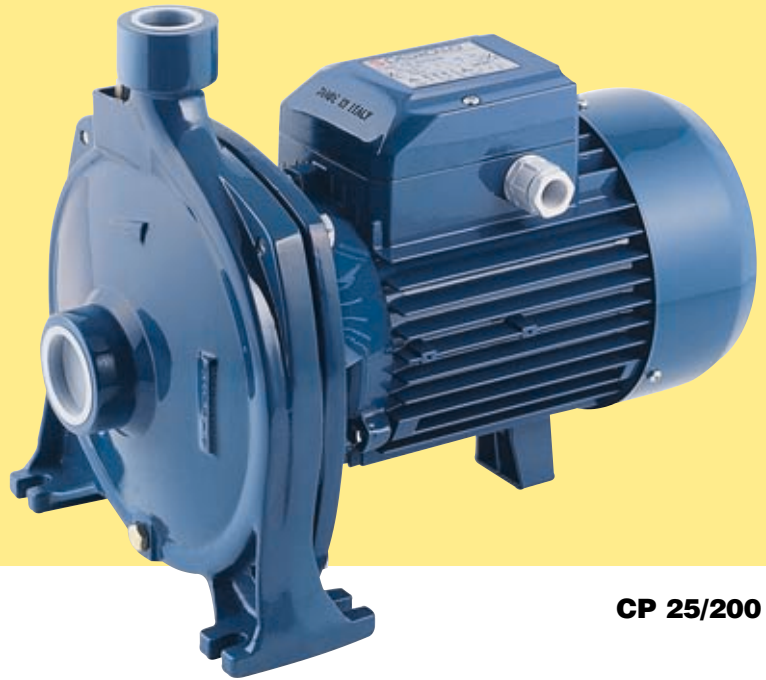

standardized centrifugal pumps (EN 733 - DIN 24255)



CP 25/200

PERFORMANCE RANGE

Flow rate up to 250 l/min (15 m³/h)
Dynamic head up to 61 m

OPERATING LIMITS

Suction lift up to 7 m
Fluid temperature up to + 60°C
Maximum ambient temperature + 40°C

CONSTRUCTION AND SAFETY STANDARDS:

EN 60 335-1	EN 60034-1
IEC 335-1	IEC 34-1
CEI 61-150	CEI 2-3

PUMP INSTALLATION AND APPLICATIONS

These pumps are suitable for pumping clean water and fluids which are not chemically aggressive to the pump components.

THIS SERIES OF PUMPS HAS BEEN SPECIFICALLY DESIGNED FOR CIVIL, INDUSTRIAL OR AGRICULTURAL USE, WHERE THEIR CHARACTERISTIC STRENGTH AND RELIABILITY CAN BE USED TO THE FULL.

Built according to EN 733 - DIN 24255, these pumps have standard overall dimensions, sizes and positioning of the delivery and suction openings, support base and other dimensions.

This means that the pumps chosen will be adequately designed to handle heavy-duty operation and can be interchanged with other standardized pumps.

These pumps should be installed in a covered area, protected against weather.

WARRANTY: 2 YEARS

(according to our general sales conditions).

STRUCTURAL CHARACTERISTICS

- **PUMP BODY:**
cast iron, built according to EN 733 - DIN 24255 and UNI 7467-NF E-44-111, with UNI ISO 228/1 gas threaded suction and delivery openings.
- **IMPELLER:**
brass, centrifugal radial flow type.
- **MOTOR SHAFT:**
AISI 430F stainless steel.
- **MECHANICAL SEAL:**
ceramic and graphite.
- **MOTOR:**
the pumps are coupled to an asynchronous, high efficiency PEDROLLO induction motor of suitable size, which is quiet, closed and externally ventilated, suitable for continuous duty. INSULATION class F.
The thermal cutout relay (motor protector) is incorporated in single phase motors up to 1.5 kW.
The remaining single phase motors and all three phase motors require an adequate external motor protector, with connections according to current standards.
- **PROTECTION:**
IP 44.



PERFORMANCE CHART AT n= 2900 1/min

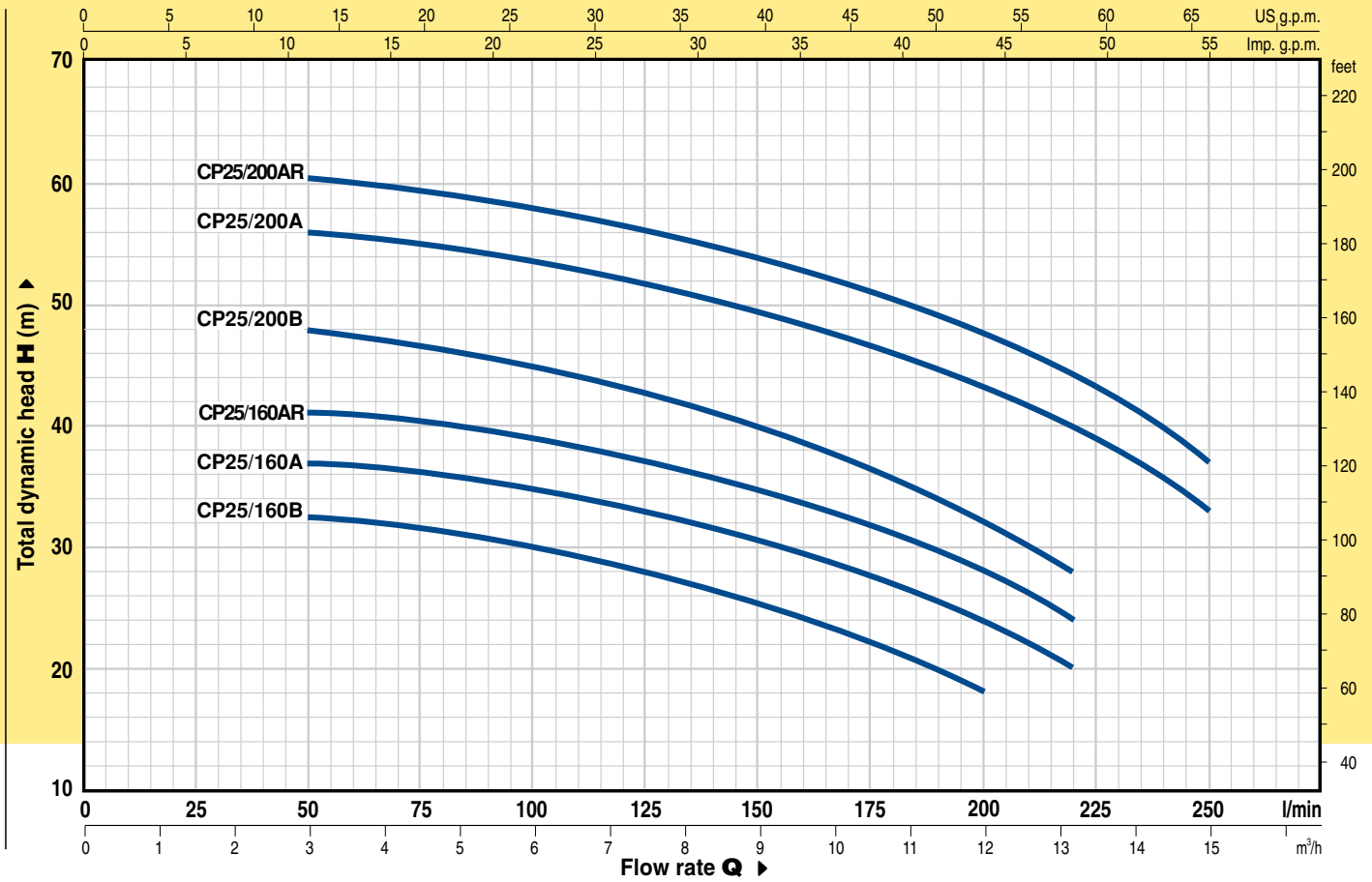

PERFORMANCE DATA AT n= 2900 1/min

PUMP MODEL		POWER		Q m³/h	H														
Single phase	Three phase	kW	HP		0	3.0	3.6	4.2	4.8	5.4	6.0	6.6	7.5	8.4	9.6	10.8	12.0	13.2	15.0
				l/min	0	50	60	70	80	90	100	110	125	140	160	180	200	220	250
CPm 25/160B	CP 25/160B	1.1	1.5	H (m)	33	32.5	32	31.5	31	30.5	30	29	28	26.5	24	21.5	18		
CPm 25/160A	CP 25/160A	1.5	2		38	37	36.8	36.5	36	35.5	35	34	33	31.5	29.5	27	24	20	
—	CP 25/160AR	2.2	3		42	41	41	40.5	40	39.5	39	38	37	36	34	31	28	24	
CPm 25/200B	CP 25/200B	2.2	3		49	48	47.5	47	46.5	45.5	45	44	43	41	38.5	36	32	28	
—	CP 25/200A	3	4		57	56	55.8	55.5	55	54.5	53.5	53	52	50.5	48.5	46	43.5	40	33
—	CP 25/200AR	4	5.5		61	60.5	60	59.5	59	58.5	58	57	56	55	53	50.5	48	44	37

Q = FLOW RATE H = TOTAL DYNAMIC HEAD IN METERS

Curve tolerance according to ISO 2548.

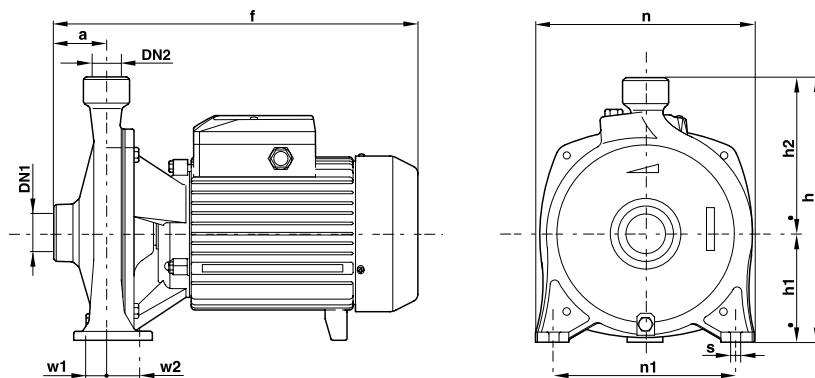

DIMENSIONS

PUMP MODEL		DN1	DN2	DIMENSIONS mm									
Single phase	Three phase			a	f	h	h1	h2	n	n1	w1	w2	s
CPm 25/160B	CP 25/160B	1 1/2"	1"	56	360	260	105	155	206	150	27.5	27.5	10
CPm 25/160A	—	1 1/2"	1"	56	380	260	105	155	206	150	27.5	27.5	10
—	CP 25/160A	1 1/2"	1"	56	360	260	105	155	206	150	27.5	27.5	10
—	CP 25/160AR	1 1/2"	1"	56	380	260	105	155	206	150	27.5	27.5	10
CPm 25/200B	—	1 1/2"	1"	60	384	305	125	180	252	210	23.5	39.5	11
—	CP 25/200B	1 1/2"	1"	60	359	305	125	180	252	210	23.5	39.5	11
—	CP 25/200A	1 1/2"	1"	60	384	305	125	180	252	210	23.5	39.5	11
—	CP 25/200AR	1 1/2"	1"	60	430	305	125	180	252	210	23.5	39.5	11