

PMC

submersible SINGLE VANE impeller pumps (for sewage)

stationary versions

High efficiency, submersible SINGLE VANE pumps in stationary version. Extremely sturdy and suitable for continuous heavy duty service on building sites and industrial use. Specifically designed for dirty water, sewage, industrial waste, etc.



PERFORMANCE RANGE

Flow rate up to 1600 l/min (96 m³/h)
Dynamic head up to 24 m

OPERATING LIMITS

Maximum operating depth 10 m
Fluid temperature up to + 50°C
Maximum passage for suspended solids Ø 70 mm

CONSTRUCTION AND SAFETY STANDARDS:

EN 60 335-1
IEC 335-1
CEI 61-150

EN 60034-1
IEC 34-1
CEI 2-3



PUMP INSTALLATION AND APPLICATIONS

PMC PUMPS ARE FITTED WITH CAST-IRON SINGLE VANE IMPELLERS, AND ARE SUITABLE FOR PUMPING LIQUIDS CONTAINING SOLIDS IN SUSPENSION, INCLUDING SHORT FIBERS. PMC PUMPS ARE PARTICULARLY RECOMMENDED FOR HANDLING WASTE WATER AND SEWAGE, REFLUENT WATER, WATER MIXED WITH MUD, GROUNDWATER AND SURFACE WATER IN AREAS SUCH AS: RESIDENTIAL HOUSING BLOCKS, PUBLIC BUILDINGS, INDUSTRIES, MULTI-STOREY CAR PARKS, CAR WASHES, IN PURPOSE BUILT PITS.

Manufactured entirely in extremely thick cast iron, these pumps are particularly sturdy, abrasion resistant and built to last. They are supplied with delivery flange, discharge connector and guide rails for fixed installation.

WARRANTY: 1 YEAR

(according to our general sales conditions).

STRUCTURAL CHARACTERISTICS

- **PUMP BODY, BASE, MOTOR CASING AND DISCHARGE CONNECTOR:**
cast iron.
- **IMPELLER:**
cast iron, single vane type.
- **SCREWS:**
AISI 304 stainless steel.
- **MOTOR SHAFT:**
AISI 304 stainless steel.
- **DOUBLE MECHANICAL SEAL:**
widia/silicon carbide on the pump side and sealing ring on the motor side (with barrier oil chamber to lubricate and cool the sealing surfaces in the absence of water).
- **MOTOR:**
sealed induction with double impregnated class F winding (ensuring extended motor life and wide range of use), designed for continuous duty, even with the pump partially submerged min. 350 mm (PMC .. /50) min. 400 mm (PMC .. /70). The thermal cutout relay (motor protector) is incorporated in single phase models.
• In the three phase versions three thermal overload cutouts (motor protectors) are placed against the windings in series connected by a grey cable. The two ends coming out from the supply cable must be properly connected to the contactor coil by the user.
- **PROTECTION:**
IP 68.
- **CONTROL BOX:**
with capacitor and motor protector with manual reset (on single phase versions). Protection IP 64.
- **SUPPLY CABLE:**
 - Single phase: 10 meters "H07 RN-F" neoprene submersible.
 - Three phase: 10 meters "FG5 0K 4 x 1.5 mm² + 2 x 0.5 mm²" neoprene submersible.
- **EXTERNAL FLOAT SWITCH:** for single phase versions.

PERFORMANCE CHART AT n= 2900 1/min

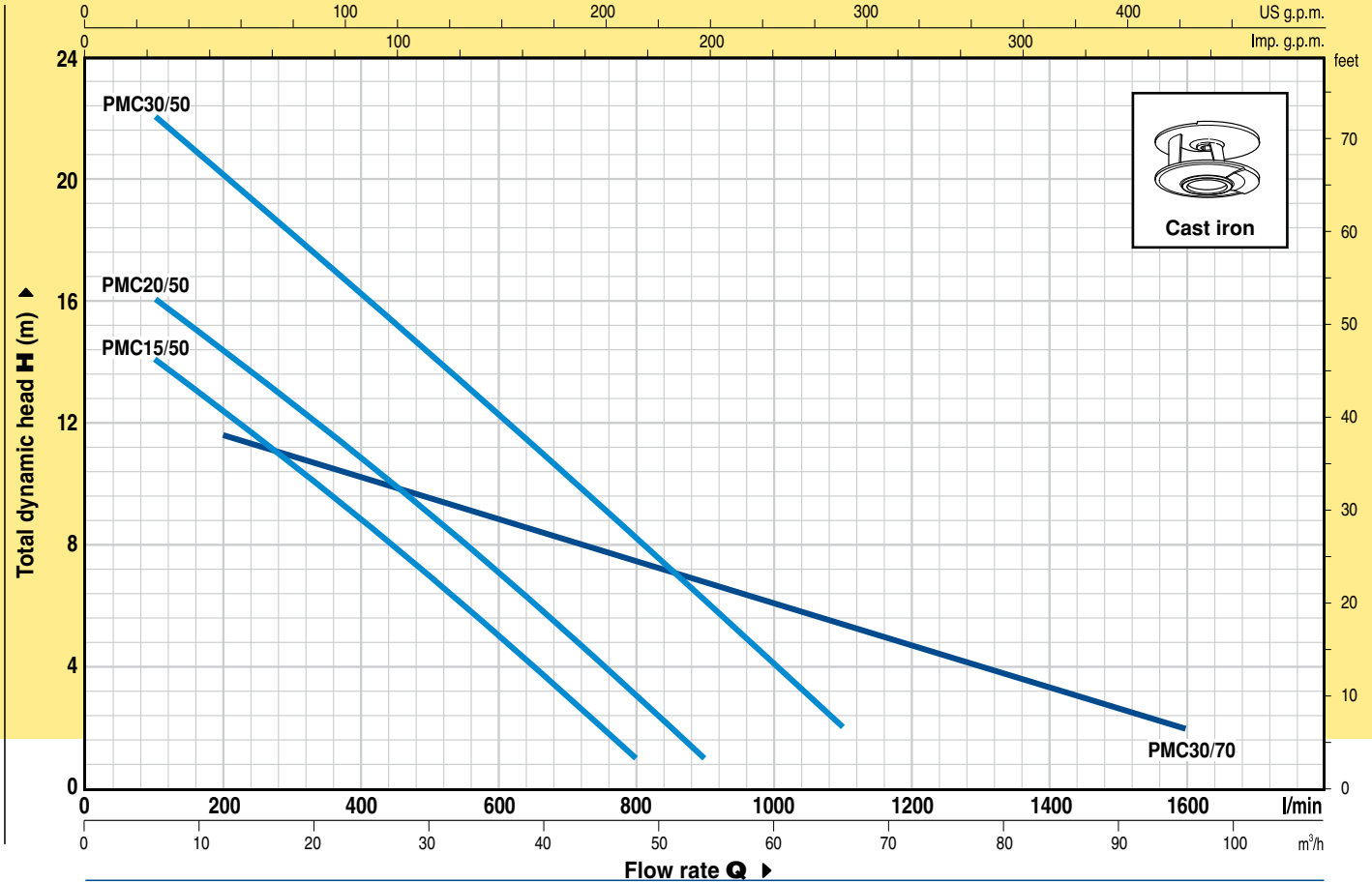

PERFORMANCE DATA AT n= 2900 1/min

PUMP MODEL		POWER		Q	0	6	12	15	18	24	30	36	42	48	54	60	66	72	84	96		
Single phase	Three phase	kW	HP	m³/h	0	100	200	250	300	400	500	600	700	800	900	1000	1100	1200	1400	1600		
—	PMC 15/50	1.1	1.5	H (m)	16	14	12.5	11.5	10.5	8.5	7	5	3	1								
—	PMC 20/50	1.5	2		18	16	14	13	12.5	10.5	9	7	5	3	1							
—	PMC 30/50	2.2	3		24	22	20	19	18	16	14	12	10	8	6	4	2					
—	PMC 30/70	2.2	3		13	—	11.5	11.2	11	10.2	9.5	8.8	8.2	7.6	6.8	6	5.3	4.8	3.2	2		

Q = FLOW RATE H = TOTAL DYNAMIC HEAD IN METERS

Curve tolerance according to ISO 2548.

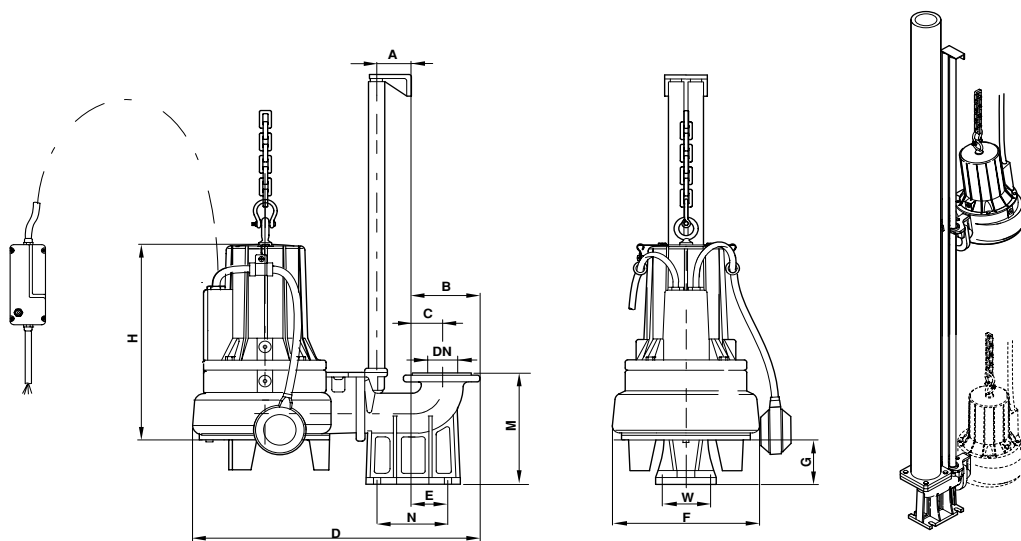

DIMENSIONS

PUMP MODEL		DN	maximum suspended solid size	DIMENSIONS mm										
Single phase	Three phase			A	B	C	D	E	F	G	H	M	N	W
PMCm 15-20/50	PMC 15-20-30/50	2 1/2"	Ø 50 mm	60	116	51	490	62	247	79.5	372	200	120	72
—	PMC 30/70	3"	Ø 70 mm	60	150	70	570	95	270	91	395	256	150	92