

# PVXC

**submersible VORTEX pumps**  
(for sewage)

## stationary versions

**Submersible VORTEX pumps in stationary version. Extremely reliable, sturdy and suitable for continuous heavy duty service on building sites and industrial use. Specifically designed for dirty water, sewage, industrial waste, etc.**



### PERFORMANCE RANGE

Flow rate up to 1200 l/min (72 m<sup>3</sup>/h)  
Dynamic head up to 16 m  
Maximum suspended solid Ø 50 mm for PVXC15-20-30/50  
Maximum suspended solid Ø 70 mm for PVXC15-20-30/70

### OPERATING LIMITS

Maximum operating depth 10 m  
Fluid temperature up to + 50°C  
Maximum passage for suspended solids Ø 70 mm

### CONSTRUCTION AND SAFETY STANDARDS:

EN 60 335-1  
IEC 335-1  
CEI 61-150

EN 60034-1  
IEC 34-1  
CEI 2-3



### PUMP INSTALLATION AND APPLICATIONS

THE FREE VORTEX TYPE RETRACTED OPEN IMPELLERS FITTED TO PVXC PUMPS ARE SUITABLE FOR HANDLING REFLUENT WATER, WATER MIXED WITH MUD, LIQUIDS CONTAINING AIR OR GAS, AS WELL AS TREATED AND PUTRID MUD. PVXC PUMPS ARE PARTICULARLY SUITABLE FOR INSTALLATION IN SEWERS, GALLERIES, WELLS, UNDERGROUND CAR PARKS, IN PURPOSE BUILT PITS.

Manufactured entirely in extremely thick cast iron, these pumps are particularly sturdy, abrasion resistant and built to last. They are supplied with delivery flange, discharge connector and guide rails for fixed installation.

### WARRANTY: 1 YEAR

(according to our general sales conditions).

### STRUCTURAL CHARACTERISTICS

- PUMP BODY, BASE, MOTOR CASING AND DISCHARGE CONNECTOR: cast iron.
- IMPELLER: cast iron, open vortex type.
- SCREWS: AISI 304 stainless steel.
- MOTOR SHAFT: AISI 304 stainless steel.
- DOUBLE MECHANICAL SEAL: **widia/silicon carbide** on the pump side and sealing ring on the motor side (with barrier oil chamber to lubricate and cool the sealing surfaces in the absence of water).
- MOTOR: sealed induction with double impregnated class F winding (ensuring extended motor life and wide range of use), designed for continuous duty, **even with the pump partially submerged min. 350 mm (PVXC ../50) min. 400 mm (PVXC ../70)**. The thermal cutout relay (motor protector) is incorporated in single phase models.  
• In the three phase versions three thermal overload cutouts (motor protectors) are placed against the windings in series connected by a grey cable. The two ends coming out from the supply cable must be properly connected to the contactor coil by the user.
- PROTECTION: IP 68.
- CONTROL BOX : with capacitor and motor protector with manual reset on single phase versions. Protection IP 64.
- SUPPLY CABLE:
  - Single phase: 10 meters "H07 RN-F" neoprene submersible.
  - Three phase: 10 meters "FG5 0K 4 x 1.5 mm<sup>2</sup> + 2 x 0.5 mm<sup>2</sup>" neoprene submersible.
- EXTERNAL FLOAT SWITCH: for single phase versions.

### PERFORMANCE CHART AT n= 2900 1/min

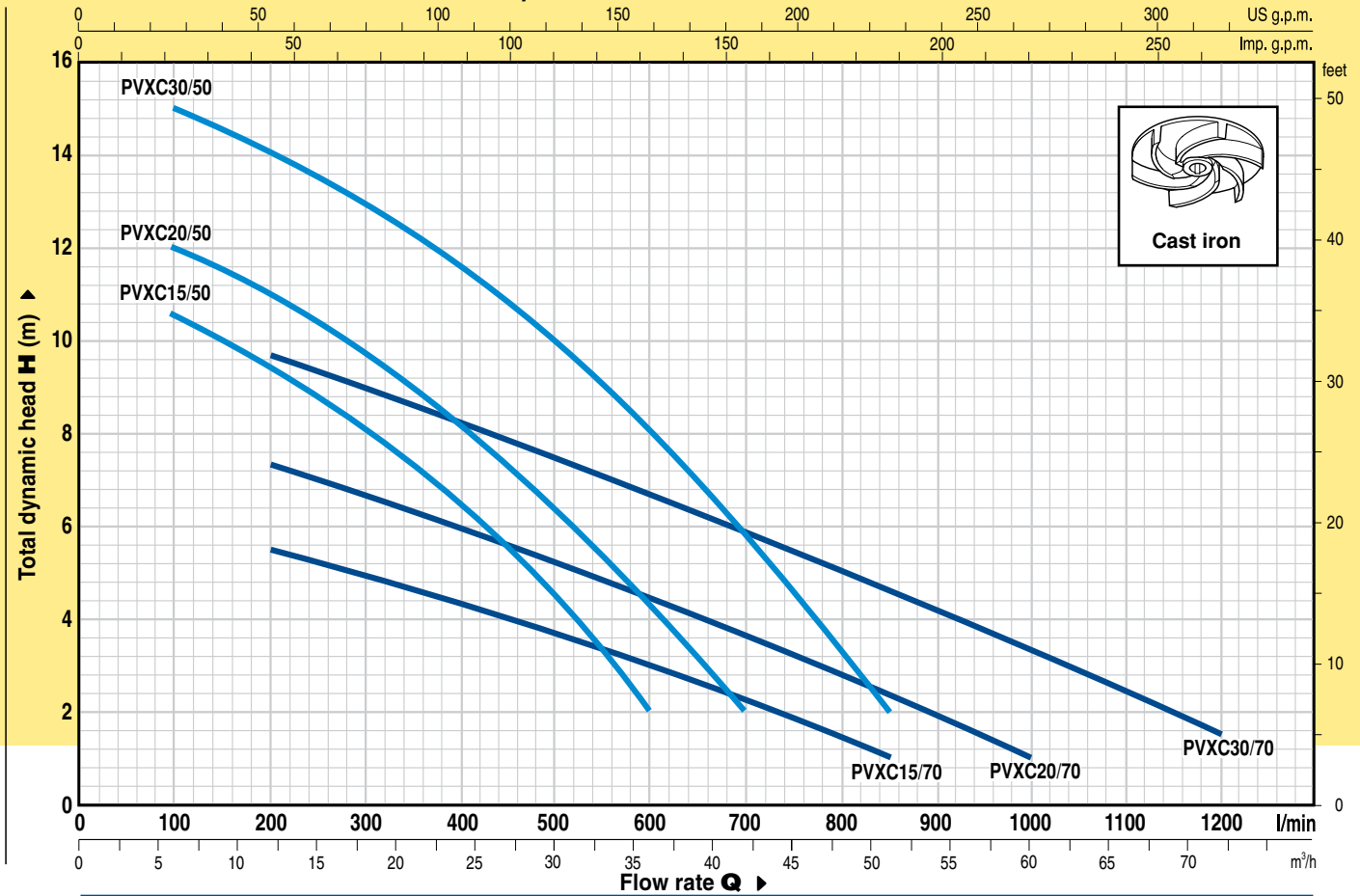

### PERFORMANCE DATA AT n= 2900 1/min

PUMP MODEL		POWER		Q																	
Single phase	Three phase	kW	HP	m³/h	0	6	12	18	21	24	27	30	36	42	48	51	54	60	66	72	
				l/min	0	100	200	300	350	400	450	500	600	700	800	850	900	1000	1100	1200	
PVXCm 15/50	PVXC 15/50	1.1	1.5	H (m)	11.5	10.5	9.5	8.2	7.2	6.5	5.6	4.5	2								
PVXCm 20/50	PVXC 20/50	1.5	2		13	12	11	9.5	9	8	7.2	6.5	4.5	2							
—	PVXC 30/50	2.2	3		16	15	14	13	12.3	11.5	10.8	10	8	5.9	3.3	2					
PVXCm 15/70	PVXC 15/70	1.1	1.5		6.5	—	5.5	5	4.7	4.4	4	3.7	3	2.2	1.5	1					
PVXCm 20/70	PVXC 20/70	1.5	2		8.5	—	7.4	6.7	6.3	6	5.6	5.2	4.5	3.6	2.8	2.4	2	1			
—	PVXC 30/70	2.2	3		11	—	9.7	9	8.6	8.2	7.8	7.5	6.7	5.8	5	4.6	4.2	3.3	2.5	1.5	

Q = FLOW RATE H = TOTAL DYNAMIC HEAD IN METERS

Curve tolerance according to ISO 2548.

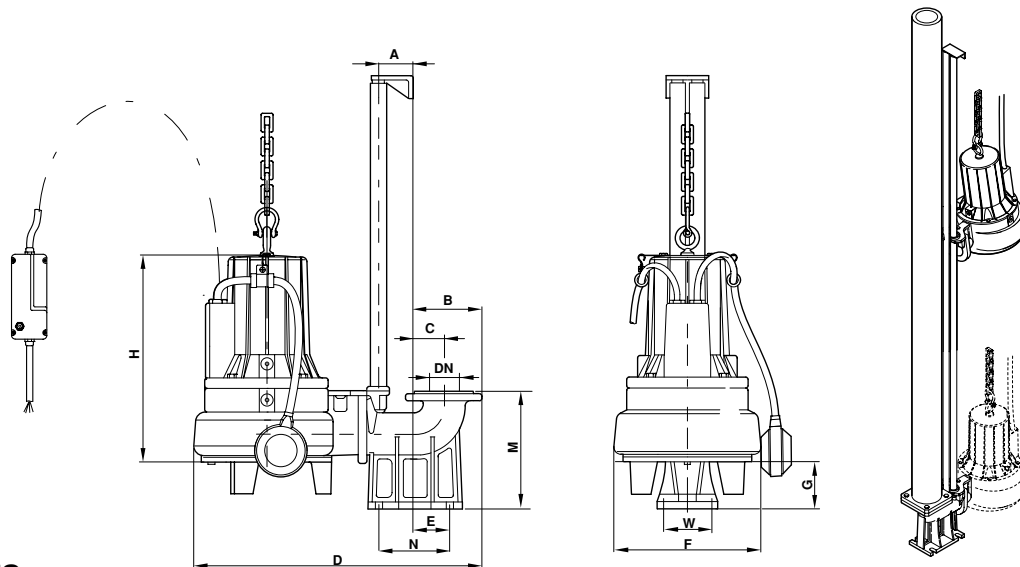

### DIMENSIONS

PUMP MODEL		DN	maximum suspended solid size	DIMENSIONS mm										
Single phase	Three phase			A	B	C	D	E	F	G	H	M	N	W
PVXCm 15-20/50	PVXC 15-20-30/50	2 1/2"	Ø 50 mm	60	116	51	490	62	247	79.5	372	200	120	72
PVXCm 15-20/70	PVXC 15-20-30/70	3"	Ø 70 mm	60	150	70	570	95	270	91	395	256	150	92