

DOC SERIES

SUBMERSIBLE PUMPS

DOC pumps are versatile, corrosion-resistant and compact. Three basic versions are available with 0.3 to 0.7 kW power.

A DOC 7VX version with Vortex impeller is available.

APPLICATIONS

- Emptying of residential sump pits, rainwater tanks or laundry drainage.
- Garden and lawn irrigation, with suction from rainwater tanks.
- Emergency draining of flooded basements and garages.
- Transfer of water from tanks, cisterns and swimming pools.

SPECIFICATIONS

- **Maximum liquid temperature: 40°C** with partially submerged pump.
- **Dry motor.**
- Maximum immersion depth: 5 m.
- **Class B insulation.**
- **IP 68 protection.**
- The **DOC 3** pump has a delivery of **145 l/min**, head up to **7 m**, and passes **suspended solids up to 10 mm** in diameter. Only available in single-phase version.
- The **DOC 7** pump has a delivery of **225 l/min**, head up to **11 m**, and passes **suspended solids up to 10 mm** in diameter.
- The **DOC 7VX** pump has a delivery of **180 l/min**, head up to **7 m**, and can handle liquids with **suspended solids up to 20 mm** in diameter.
- A "shallow-suction device", that can be mounted on both the DOC3 and DOC7 models, is available on request. It ensures complete drainage of flooded floors (to 3 mm from floor).
- Versions:
 - Single-phase** 220 V 50 Hz 2 poles (2850 rpm).
 - Three-phase** 380-415 V 50 Hz 2 poles (2850 rpm).
- 60 Hz and without floats (SG) models are available on request or tube float switch.



- **The single-phase versions feature:**
 - Pre-assembled float** for automatic pump operation (version without float available on request SG).
 - Built-in capacitor.**
 - Thermal overload protection** to stop pump supply in case of overheating.

LAB-LIP SEAL SYSTEM

- The electric motor is protected by **three lip seals**.
An **impeller counterblade** system keeps solid particles away from the seal unit to prevent damage to the lip seals and ensure their long-lasting efficiency. A double **Labyrinth** and a **V-ring** on the shaft have also been provided.

TABLE OF MATERIALS

PART	MATERIAL
Pump body, Suction screen, Handle, Upper support, Impeller	NORYL TECHNOPOLYMER
Outer sleeve, Motor casing, Lower cover, Screws and tie-rods	STAINLESS STEEL (AISI 304 - DIN 1.4301)
Shaft extension	STAINLESS STEEL (AISI 416 - DIN 1.4005)
Elastomers	NITRILE RUBBER (NBR)

DOC SERIES OPERATING CHARACTERISTICS AT 2850 rpm 50 Hz

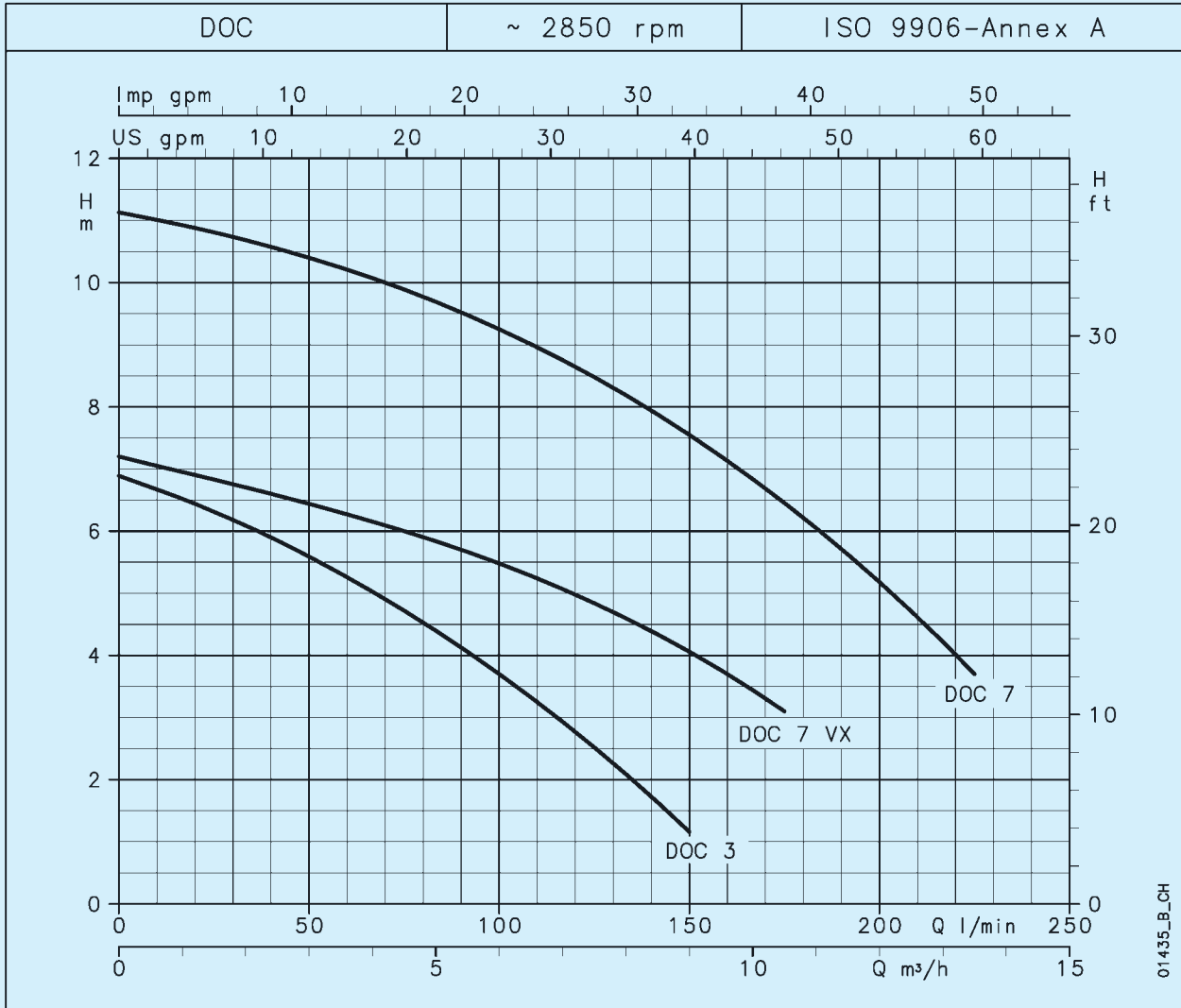

DOC

PUMP TYPE	RATED POWER		Q = DELIVERY									
			l/min	25	50	75	100	125	150	175	225	
			m³/h	0	1.5	3	4.5	6	7.5	9	10.5	13.5
			H = TOTAL HEAD METERS COLUMN OF WATER									
DOC3	0.25	0.33	6.9	6.3	5.6	4.7	3.7	2.5	1.2			
DOC7(T)	0.55	0.75	11.1	10.8	10.4	9.9	9.3	8.5	7.6	6.5	3.7	
DOC7VX(T)	0.55	0.75	7.2	6.8	6.4	6.0	5.5	4.8	4.1	3.1		

These performances are valid for liquids with density $\rho = 1.0 \text{ kg/dm}^3$ and kinematic viscosity $\gamma = 1 \text{ mm}^2/\text{sec}$.

doc-2p50_a th

PUMP TYPE	INPUT POWER*	INPUT CURRENT*	CAPACITOR
SINGLE-PHASE		220-240 V	
	kW	A	$\mu\text{F} / 450 \text{ V}$
DOC 3	0.31	1.43	6.3
DOC 7	0.78	3.47	16
DOC 7VX	0.66	2.96	16

PUMP TYPE	INPUT POWER*	INPUT CURRENT*	INPUT CURRENT*
THREE-PHASE		220-240 V	380-415 V
	kW	A	A
-	-	-	-
DOC 7T	0.79	2.82	1.63
DOC 7VXT	0.66	2.68	1.55

* Maximum value in specified range

doc-2p50_a_te

INSTALLATION DIAGRAM

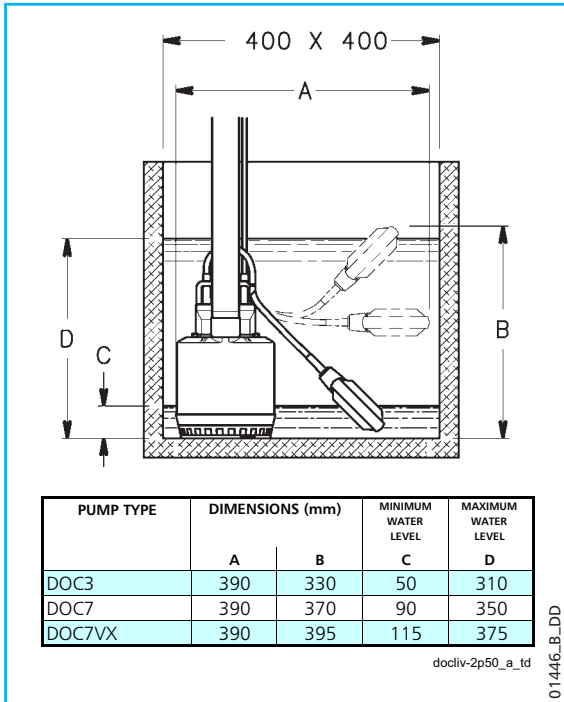

This float switch allows the pump to be used where standard float design cannot work due to insufficient space. The pump with this system can only be installed vertically and can only be used with clean water.

For pump installations that use the tube float switch, the level of start and stop are fixed, therefore they cannot be modified.

DOC SERIES DIMENSIONS AND WEIGHTS

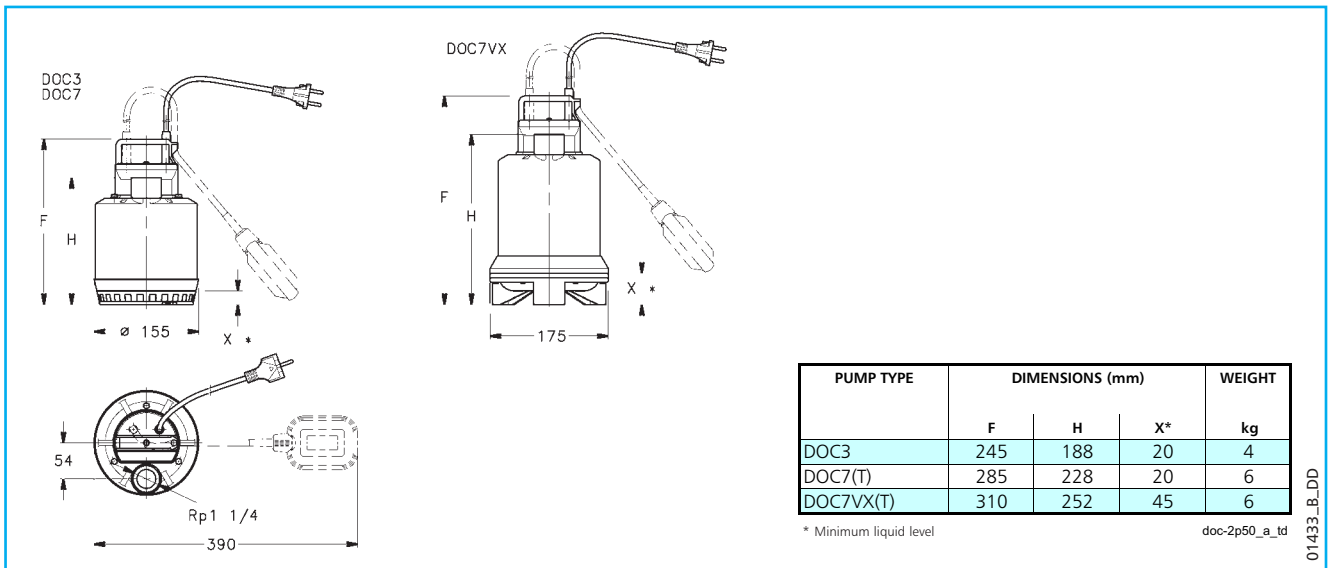

ACCESSORIES

