

DOMINO

SINGLE-PHASE ELECTRIC PUMP COMMAND AND CONTROL EQUIPMENT

Domino is a compact and functional device controlled by an electronic circuit, consisting of a diaphragm and retaining spring system integrated by delivery and pressure sensors.

It is designed to replace traditional pressure boosting systems for domestic use (consisting of a pressure switch, expansion tank, pressure gauge and fittings); it offers the advantage of smaller overall dimensions and no routine maintenance is required.

Moreover, Domino provides the electric pump with adequate protection against dry running. The starting pressure setting ranges from 1.5 to 3 bar.

It can be coupled to single-phase pumps with a maximum input current of 10 A, and developing a head at least 0.5 to 0.7 bar greater than the minimum starting pressure setting. It is made of a non-toxic plastic material suitable for the handling of drinking water.

APPLICATIONS

- Pressure boosting in domestic and civil applications.
- Automatic lawn sprinkler systems.

SPECIFICATIONS

- **Voltage: 220-240 V** single-phase.
- **Frequency: 50/60 Hz.**
- Maximum current: 10 A.
- IP 65 protection.
- **Maximum pressure: 10 bar.**
- **Adjustable minimum starting pressure: 1,5 to 3 bar.**



- Differential pressure: 0.5 to 0.7 bar.
- R 1" pump and user connector.
- **Maximum liquid temperature: 35° C.**
- Non-toxic plastic material, suitable for handling drinking water.
- **Protection against dry running.**
- Pressure gauge (0-10 bar).
- Manual reset button.
- Mains power supply (POWER) indicator light (green).
- Pump running (ON) indicator light (yellow).
- Dry running (FAILURE) protection system activation indicator light (red).
- **Delivery up to 170 l/min.** (10 m³/h).
- **Low friction loss** (see diagram next page).
- Approx. overall dimensions: 100 x 150 x 200 mm.

INSTALLATION DIAGRAM

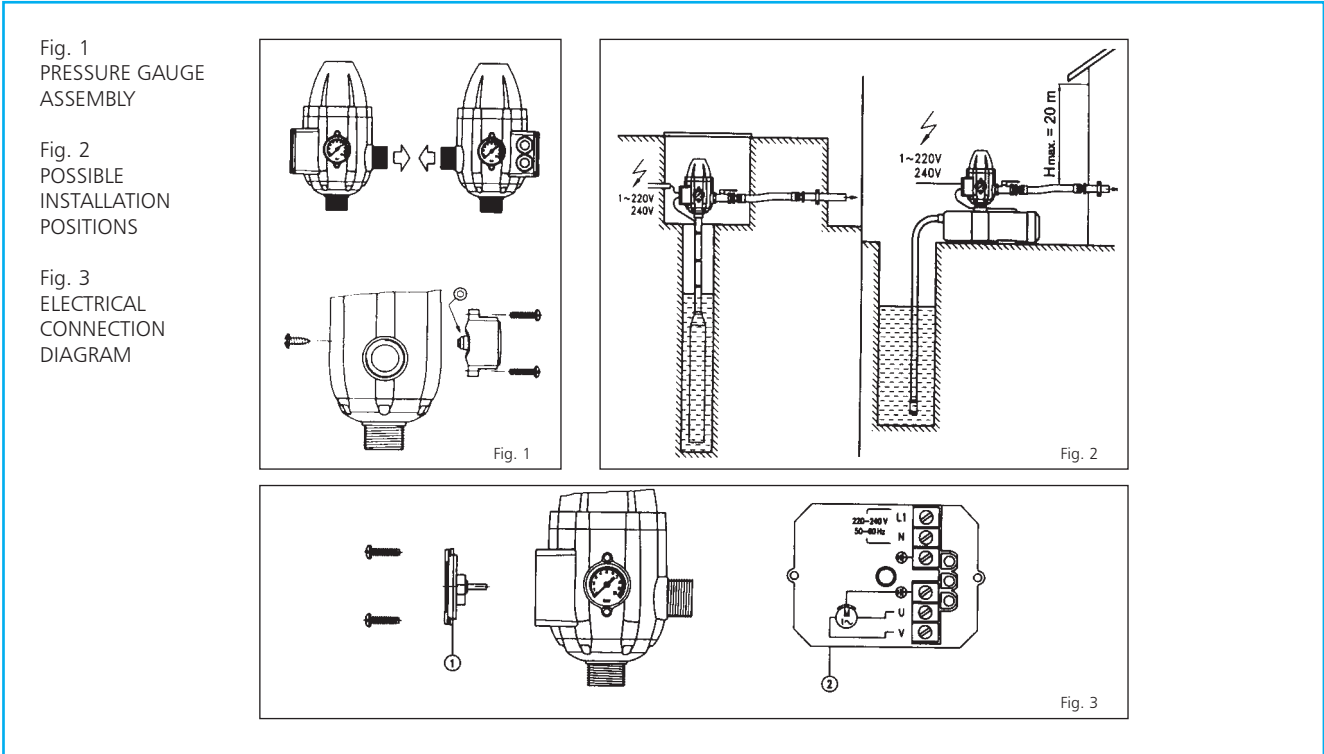

FRICTION LOSS

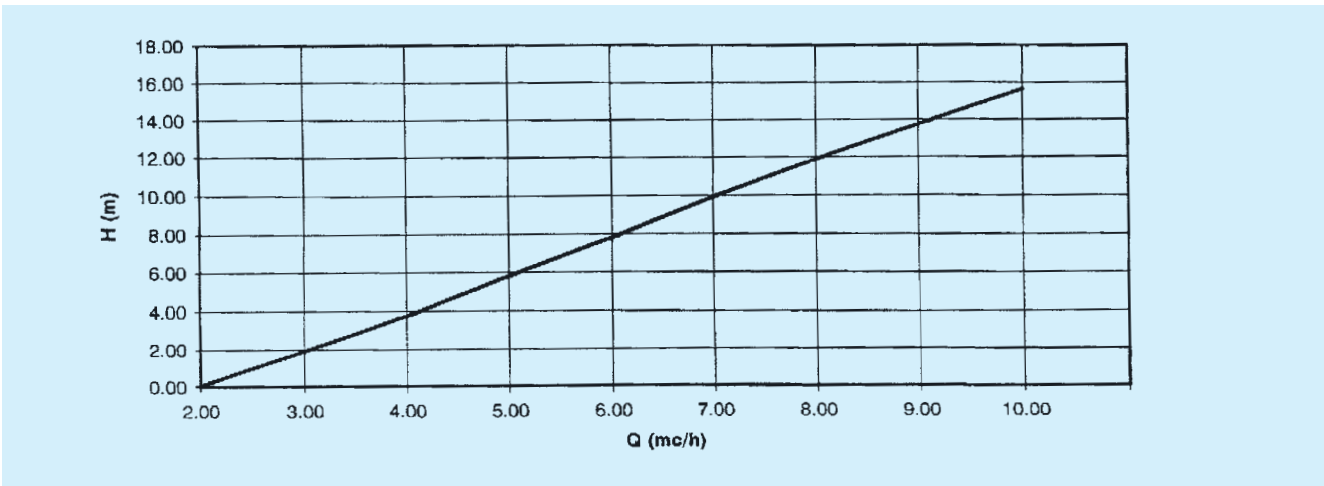

**MINIMUM STARTING PRESSURE SETTING
(1,5 to 3 bar)**

