

# DOMO SERIES

## SUBMERSIBLE PUMPS WITH ENTRAINED SOLIDS

DOMO series electric pumps are available with twin-channel or vortex impeller (DOMO VX). Designed to handle suspended solids up to 50 mm in diameter (35 mm for DOMO 7 and DOMO 7VX).

Four basic models with 0.55 (0.75 HP) to 1.5 kW (2HP) rated power.

### DRIVELUB SEAL SYSTEM.

### APPLICATIONS

- Pumping of effluent (VX model handles also suspended filaments).
- Emptying of septic tanks and residential sumps.
- Draining of flooded basements and garages.

### SPECIFICATIONS

- **Capacity** up to **40 m<sup>3</sup>/h**.
- **Head** up to **14,8 m**.
- **Continuous duty** with **35°C** liquids and fully submerged pump.
- **Dry motor** (class F insulation).
- **IP 68 protection**.
- **H07RN-F** type neoprene power **cord**.
- **Maximum immersion depth: 5 m**.
- Versions:
  - Single-phase** 220-240 V 50 Hz 2 poles.
  - Three-phase** 380-415 V 50 Hz 2 poles.
- **Motor power:**
  - 0.55 to 1.1 kW for single-phase versions.**
  - 0.55 to 1.5 kW for three-phase versions.**
- The single-phase versions feature:
  - Pre-assembled float** (version without float available on request).
  - Built-in capacitor** (except for DOMO 15 and DOMO 15 VX models with control box on cable).
  - Thermal overload protection.**
- The **DOMO 7** and **DOMO 7VX** versions feature:
  - Rp 1 1/2" delivery port (female gas).
  - Handling of suspended **solids up to 35 mm** in diameter.
  - **Fiberglass-reinforced nylon impeller** (stainless steel impeller also available).



- The **DOMO 10-15-20** and **DOMO 10-15-20VX** versions feature:
  - **2" delivery port**, female ASP (can be turned into a flanged version if an optional accessory is installed).
  - Handling of suspended **solids up to 50 mm** in diameter.
  - **Stainless steel twin-channel or vortex impeller.**
  - **Tube float switch.**

### DRIVELUB SEAL SYSTEM

- Watertight electric motor protected by multiple seal system with **oil chamber**. **A V-ring** and **silicon carbide mechanical seal** (extremely resistant to wear and abrasion), as well as a **lip seal** which is continuously lubricated by the **DRIVELUB system**, provide an extremely efficient barrier against infiltration.

### TABLE OF MATERIALS

PART	MATERIAL
Pump body, Motor casing	STAINLESS STEEL (AISI 304 - DIN 1.4301)
DOMO 7 (VX) impeller	FIBREGLASS-REINFORCED NYLON
DOMO 10-15-20 (VX) impeller	STAINLESS STEEL (AISI 304 - DIN 1.4301)
Inner mechanical seal	SILICON CARBIDE/SILICON CARBIDE
Upper lip seal	NITRILE RUBBER
Shaft extension	STAINLESS STEEL (AISI 304 - DIN 1.4301)
Handle	NYLON

**DOMO SERIES (TWIN CHANNEL IMPELLER)  
OPERATING CHARACTERISTICS AT 2850 rpm 50 Hz**

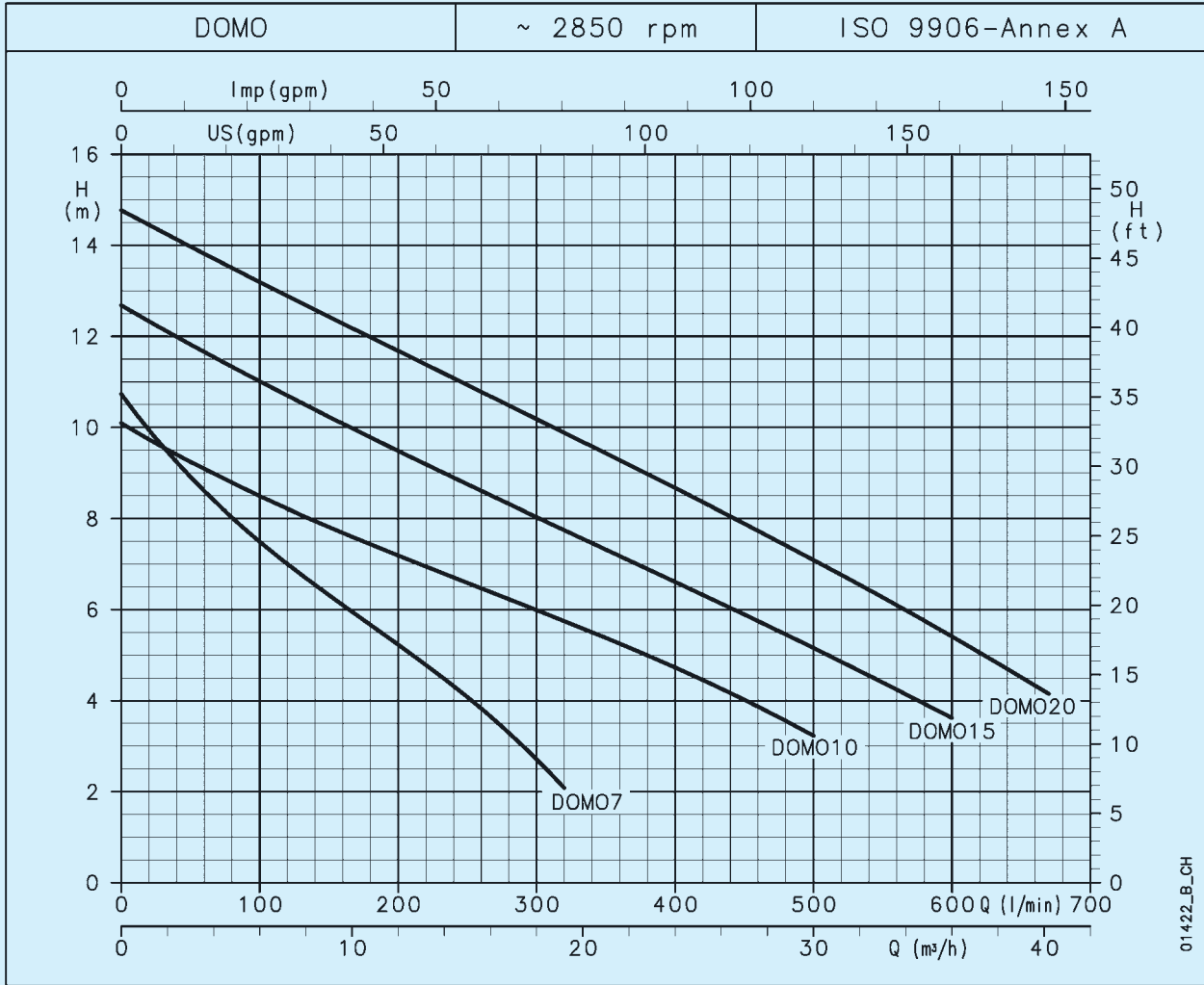

**DOMO**

PUMP TYPE	RATED POWER		Q = DELIVERY												
			l/min	0	50	100	150	200	250	300	320	400	500	600	670
	kW	HP	m³/h	0	3	6	9	12	15	18	19.2	24	30	36	40.2
			H = TOTAL HEAD METERS COLUMN OF WATER												
DOMO 7(T)	0.55	0.75	10.7	8.9	7.5	6.3	5.2	4.1	2.7	2.1					
DOMO 10(T)	0.75	1	10.1	9.2	8.5	7.8	7.2	6.6	6.0	5.8	4.7	3.2			
DOMO 15(T)	1.1	1.5	12.7	11.8	11.0	10.2	9.5	8.8	8.0	7.8	6.6	5.2	3.6		
DOMO 20T	1.5	2	14.8	14.0	13.2	12.4	11.7	10.9	10.2	9.9	8.7	7.1	5.4	4.2	

These performances are valid for liquids with density  $\rho = 1.0 \text{ kg/dm}^3$  and kinematic viscosity  $\gamma = 1 \text{ mm}^2/\text{sec}$ .

domo-2p50\_a\_th

PUMP TYPE	INPUT POWER*	INPUT CURRENT*	CAPACITOR
SINGLE-PHASE		220-240 V	
	kW	A	$\mu\text{F} / 450 \text{ V}$
DOMO 7	0.80	3.94	16
DOMO 10	1.14	5.84	22
DOMO 15	1.58	7.02	30
-	-	-	-

PUMP TYPE	INPUT POWER*	INPUT CURRENT*	INPUT CURRENT*
THREE-PHASE		220-240 V	380-415 V
	kW	A	A
DOMO 7T	0.73	2.58	1.49
DOMO 10T	1.09	4.09	2.36
DOMO 15T	1.49	4.73	2.73
DOMO 20T	1.96	6.6	3.81

\* Maximum value in specified range

domo-2p50\_a\_th

## DOMO VX SERIES (VORTEX IMPELLER) OPERATING CHARACTERISTICS AT 2850 rpm 50 Hz

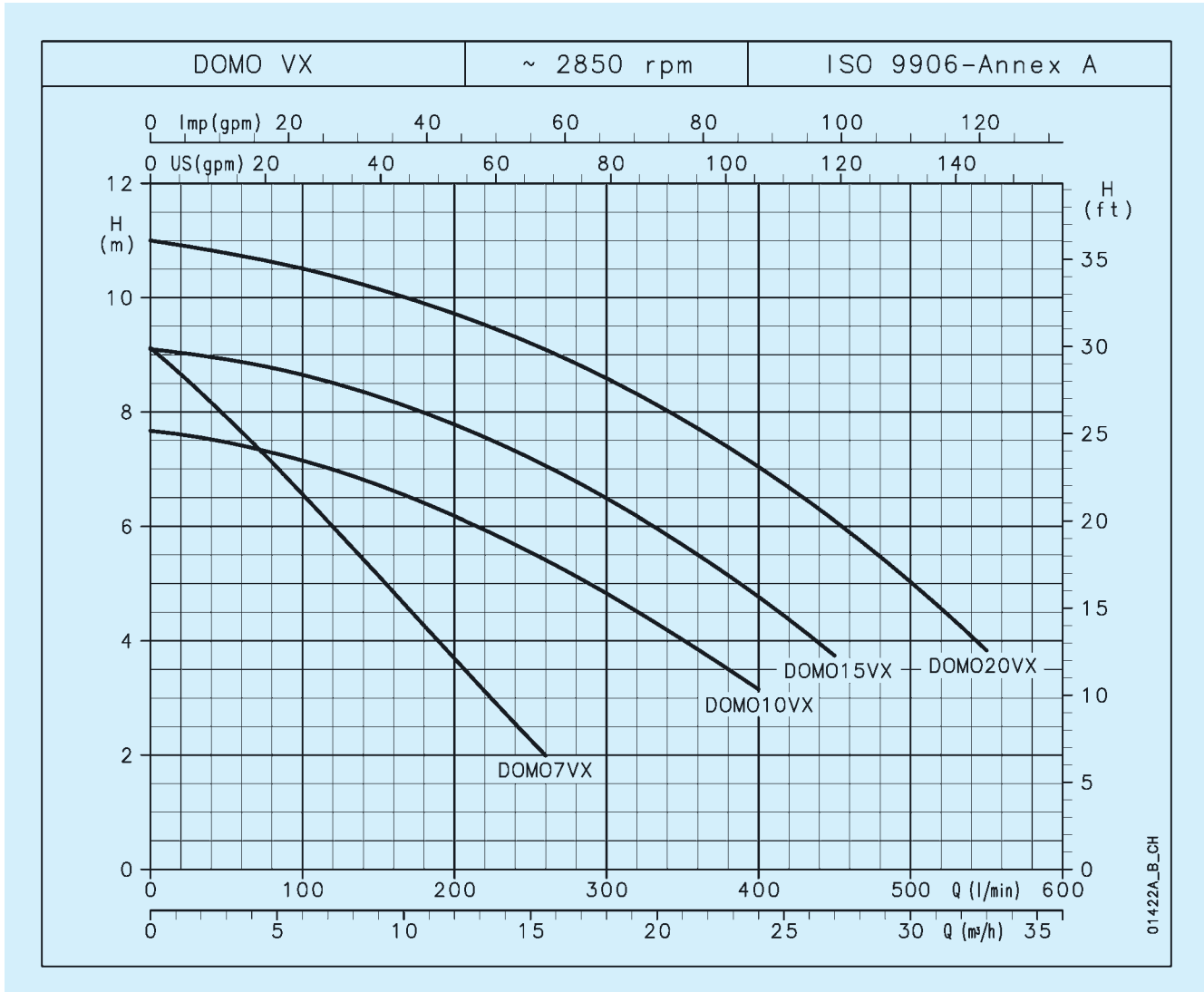

**DOMO**

PUMP TYPE	RATED POWER		Q = DELIVERY												
			H = TOTAL HEAD METERS COLUMN OF WATER												
			l/min	80	100	150	175	200	225	260	300	400	450	550	
			m <sup>3</sup> /h	0	4.8	6	9	10.5	12	13.5	15.6	18	24	27	33
DOMO 7VX(T)	0.55	0.75	9.1	7.1	6.6	5.1	4.4	3.7	3.0	2.0					
DOMO 10VX(T)	0.75	1	7.7	7.3	7.1	6.7	6.5	6.2	5.9	5.4	4.8	3.1			
DOMO 15VX(T)	1.1	1.5	9.1	8.8	8.6	8.3	8.0	7.8	7.5	7.1	6.5	4.8	3.7		
DOMO 20VXT	1.5	2	11.0	10.6	10.5	10.2	9.9	9.7	9.5	9.1	8.6	7.0	6.1	3.8	

These performances are valid for liquids with density  $\rho = 1.0 \text{ kg/dm}^3$  and kinematic viscosity  $\gamma = 1 \text{ mm}^2/\text{sec}$ .

domovx-2p50\_a\_th

PUMP TYPE	INPUT POWER*	INPUT CURRENT*	CAPACITOR
SINGLE-PHASE		220-240 V	
	kw	A	$\mu\text{F} / 450 \text{ V}$
DOMO 7VX	0.79	3.91	16
DOMO 10VX	1.15	5.88	22
DOMO 15VX	1.36	6.11	30
-	-	-	-

PUMP TYPE	INPUT POWER*	INPUT CURRENT*	INPUT CURRENT*
THREE-PHASE		220-240 V	380-415 V
	kw	A	A
DOMO 7VXT	0.71	2.56	1.48
DOMO 10VXT	1.10	4.09	2.36
DOMO 15VXT	1.26	4.31	2.49
DOMO 20VXT	1.74	6.22	3.59

\* Maximum value in specified range

domovx-2p50\_a\_th

## DOMO SERIES DIMENSIONS AND WEIGHTS

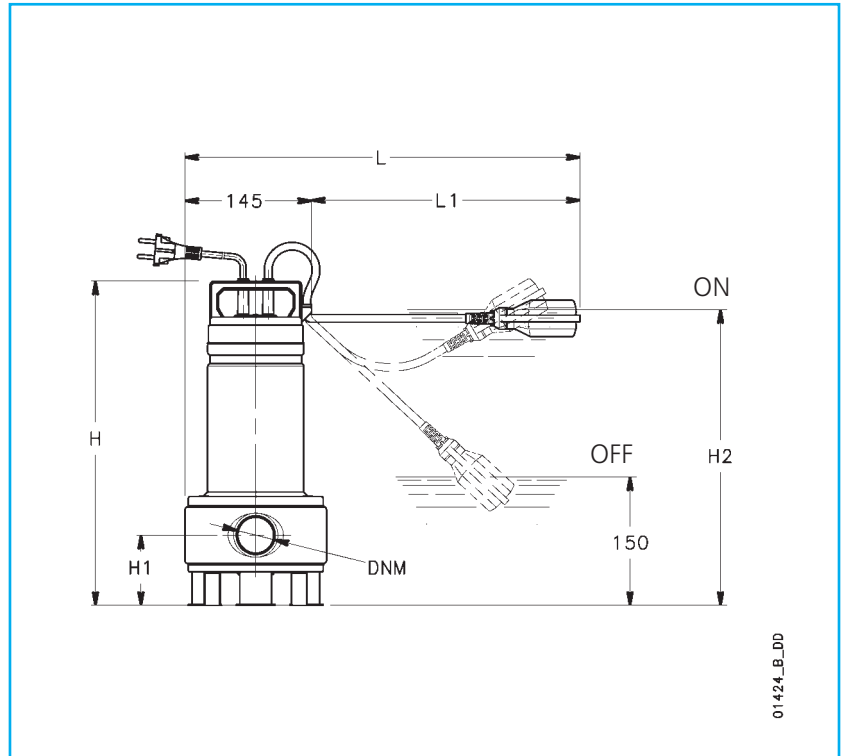
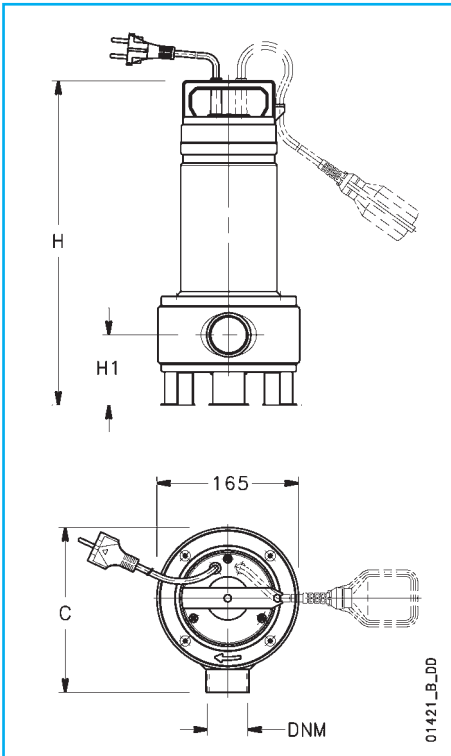

PUMP TYPE	DIMENSIONS (mm)						DNM	WEIGHT kg
	H	H1	H2	L	L1	C		
DOMO7-DOMO7VX	386	88	370	420	275	193	Rp 1½	10
DOMO10-DOMO10VX	463	111.5	415	495	350	198	Rp 2	13.4
DOMO15-DOMO15VX	463	111.5	415	495	350	198	Rp 2	15.1
DOMO7T-DOMO7VXT	386	88	-	-	-	193	Rp 1½	8.7
DOMO10T-DOMO10VXT	433	111.5	-	-	-	198	Rp 2	11.4
DOMO15T-DOMO15VXT	463	111.5	-	-	-	198	Rp 2	13.4
DOMO20T-DOMO20VXT	463	111.5	-	-	-	198	Rp 2	14.4

domo-2p50\_a\_td



This float switch allows the pump to be used where standard float design cannot work due to insufficient space. The pump with this system can only be installed vertically and can only be used with clean water.

For pump installations that use the tube float switch, the level of start and stop are fixed, therefore they cannot be modified.