

DOMO SERIES

SUBMERSIBLE PUMPS WITH ENTRAINED SOLIDS

DOMO series electric pumps are available with twin-channel or vortex impeller (DOMO VX). Designed to handle suspended solids up to 50 mm in diameter (35 mm for DOMO 7 and DOMO 7VX).

Four basic models with 0.55 (0.75 HP) to 1.5 kW (2HP) rated power.

DRIVELUB SEAL SYSTEM.

APPLICATIONS

- Pumping of effluent (VX model handles also suspended filaments).
- Emptying of septic tanks and residential sumps.
- Draining of flooded basements and garages.
- Water display, fountains.

SPECIFICATIONS

- **Capacity** up to **40 m³/h**.
- **Head** up to **14,8 m**.
- **Continuous duty** with **35°C** liquids and fully submerged pump.
- **Dry motor** (class F insulation).
- **IP 68 protection**.
- **HO7RN-F** type neoprene power **cord**.
- **Maximum immersion depth: 5 m**.
- Versions:
 - Single-phase** 220-240 V 50 Hz 2 poles.
 - Three-phase** 380-415 V 50 Hz 2 poles.
- **Motor power:**
 - 0.55 to 1.1 kW for single-phase versions.**
 - 0.55 to 1.5 kW for three-phase versions.**
- The single-phase versions feature:
 - Pre-assembled float** (version without float available on request).
 - Built-in capacitor** (except for DOMO 15 and DOMO 15 VX models with control box on cable).
 - Thermal overload protection.**
- The **DOMO 7** and **DOMO 7VX** versions feature:
 - Rp 1½" delivery port (female gas).
 - Handling of suspended **solids up to 35 mm** in diameter.
 - **Fiberglass-reinforced nylon impeller** (stainless steel impeller also available).



- The **DOMO 10-15-20** and **DOMO 10-15-20VX** versions feature:
 - **2" delivery port**, female ASP (can be turned into a flanged version if an optional accessory is installed).
 - Handling of suspended **solids up to 50 mm** in diameter.
 - **Stainless steel twin-channel or vortex impeller.**
 - **Tube float switch.**

DRIVELUB SEAL SYSTEM

- Watertight electric motor protected by multiple seal system with **oil chamber**.
A V-ring and **silicon carbide mechanical seal** (extremely resistant to wear and abrasion), as well as a **lip seal** which is continuously lubricated by the **DRIVELUB system**, provide an extremely efficient barrier against infiltration.

TABLE OF MATERIALS

PART	MATERIAL
Pump body, Motor casing	STAINLESS STEEL (AISI 304 - DIN 1.4301)
DOMO 7 (VX) impeller	FIBREGLASS-REINFORCED NYLON
DOMO 10-15-20 (VX) impeller	STAINLESS STEEL (AISI 304 - DIN 1.4301)
Inner mechanical seal	SILICON CARBIDE/SILICON CARBIDE
Upper lip seal	NITRILE RUBBER
Shaft extension	STAINLESS STEEL (AISI 304 - DIN 1.4301)
Handle	NYLON

OPERATING CHARACTERISTICS AT 2850 rpm 50 Hz

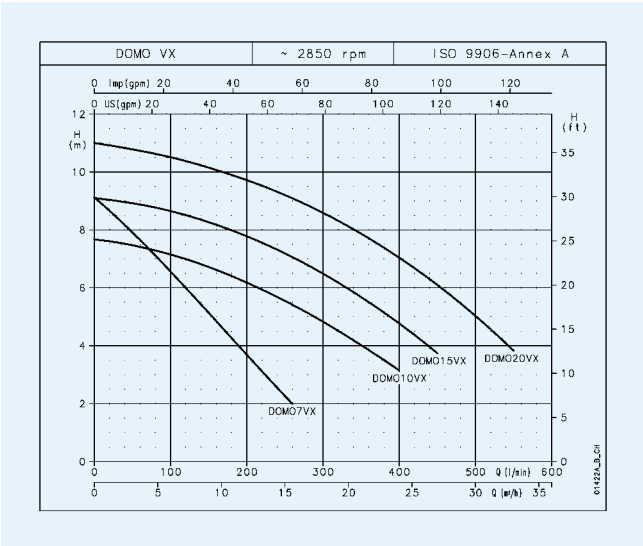
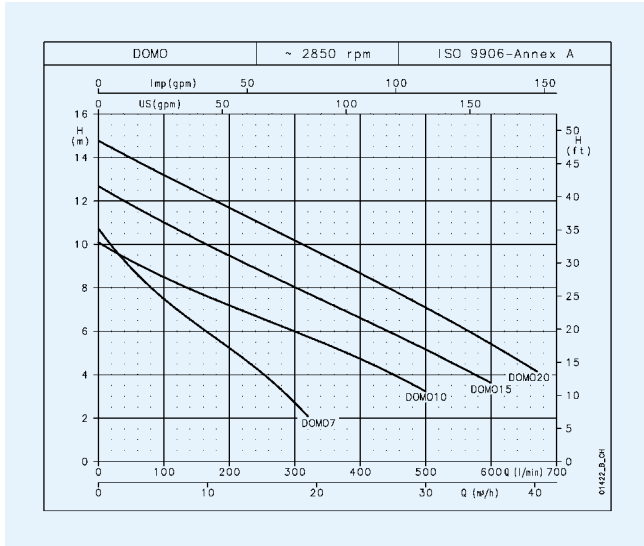

PUMP TYPE	RATED POWER		Q = DELIVERY												
	kW	HP	l/min	0	50	100	150	200	250	300	320	400	500	600	670
DOMO 7(T)	0.55	0.75	10.7	8.9	7.5	6.3	5.2	4.1	2.7	2.1					
DOMO 10(T)	0.75	1	10.1	9.2	8.5	7.8	7.2	6.6	6.0	5.8	4.7	3.2			
DOMO 15(T)	1.1	1.5	12.7	11.8	11.0	10.2	9.5	8.8	8.0	7.8	6.6	5.2	3.6		
DOMO 20(T)	1.5	2	14.8	14.0	13.2	12.4	11.7	10.9	10.2	9.9	8.7	7.1	5.4	4.2	

These performances are valid for liquids with density $\rho = 1.0 \text{ kg/dm}^3$ and kinematic viscosity $\gamma = 1 \text{ mm}^2/\text{sec}$. domo-2p50_a_th

PUMP TYPE	INPUT POWER*	INPUT CURRENT*	CAPACITOR
SINGLE-PHASE	kW	220-240 V A	$\mu\text{F} / 450 \text{ V}$
DOMO 7	0.80	3.94	16
DOMO 10	1.14	5.84	22
DOMO 15	1.58	7.02	30
-	-	-	-

PUMP TYPE	INPUT POWER*	INPUT CURRENT*	INPUT CURRENT*
THREE-PHASE	kW	220-240 V A	380-415 V A
DOMO 7T	0.73	2.58	1.49
DOMO 10T	1.09	4.09	2.36
DOMO 15T	1.49	4.73	2.73
DOMO 20T	1.96	6.6	3.81

* Maximum value in specified range

domo-2p50_a_te

PUMP TYPE	RATED POWER		Q = DELIVERY												
	kW	HP	l/min	0	80	100	150	175	200	225	260	300	400	450	550
DOMO 7VX(T)	0.55	0.75	9.1	7.1	6.6	5.1	4.4	3.7	3.0	2.0					
DOMO 10VX(T)	0.75	1	7.7	7.3	7.1	6.7	6.5	6.2	5.9	5.4	4.8	3.1			
DOMO 15VX(T)	1.1	1.5	9.1	8.8	8.6	8.3	8.0	7.8	7.5	7.1	6.5	4.8	3.7		
DOMO 20VX(T)	1.5	2	11.0	10.6	10.5	10.2	9.9	9.7	9.5	9.1	8.6	7.0	6.1	3.8	

These performances are valid for liquids with density $\rho = 1.0 \text{ kg/dm}^3$ and kinematic viscosity $\gamma = 1 \text{ mm}^2/\text{sec}$. domovx-2p50_a_th

PUMP TYPE	INPUT POWER*	INPUT CURRENT*	CAPACITOR
SINGLE-PHASE	kW	220-240 V A	$\mu\text{F} / 450 \text{ V}$
DOMO 7VX	0.79	3.91	16
DOMO 10VX	1.15	5.88	22
DOMO 15VX	1.36	6.11	30
-	-	-	-

PUMP TYPE	INPUT POWER*	INPUT CURRENT*	INPUT CURRENT*
THREE-PHASE	kW	220-240 V A	380-415 V A
DOMO 7VXT	0.71	2.56	1.48
DOMO 10VXT	1.10	4.09	2.36
DOMO 15VXT	1.26	4.31	2.49
DOMO 20VXT	1.74	6.22	3.59

* Maximum value in specified range

domovx-2p50_a_te

This float switch allows the pump to be used where standard float design cannot work due to insufficient space. The pump with this system can only be installed vertically and can only be used with clean water.

For pump installations that use the tube float switch, the level of start and stop are fixed, therefore they cannot be modified.

DOMO SERIES DIMENSIONS AND WEIGHTS

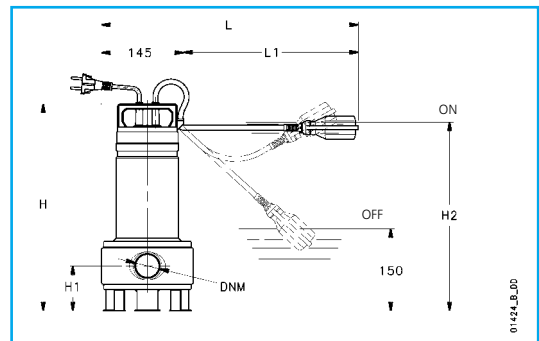
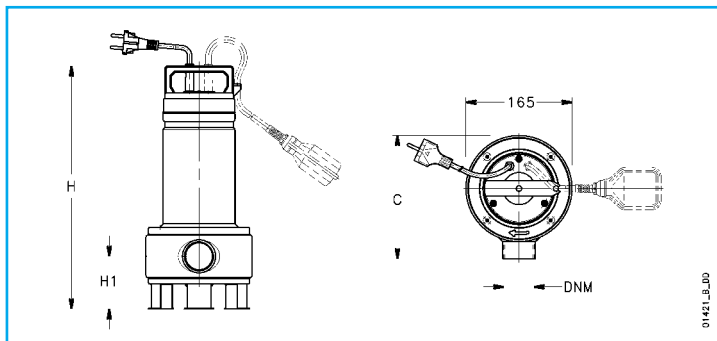

PUMP TYPE	DIMENSIONS (mm)						DNM	WEIGHT kg
	H	H1	H2	L	L1	C		
DOMO7-DOMO7VX	386	88	370	420	275	193	Rp 1½	10
DOMO10-DOMO10VX	463	111.5	415	495	350	198	Rp 2	13.4
DOMO15-DOMO15VX	463	111.5	415	495	350	198	Rp 2	15.1
DOMO7T-DOMO7VXT	386	88	-	-	-	193	Rp 1½	8.7
DOMO10T-DOMO10VXT	433	111.5	-	-	-	198	Rp 2	11.4
DOMO15T-DOMO15VXT	463	111.5	-	-	-	198	Rp 2	13.4
DOMO20T-DOMO20VXT	463	111.5	-	-	-	198	Rp 2	14.4

domo-2p50_a_ld



36075 Montecchio Maggiore - Vicenza - Italy
Tel. 0444/707111 - Fax 0444/492166 - <http://www.lowara.com>

Lowara reserves the right to make modifications without prior notice.

cod. 191004641 02/03

Lowara

