

HYDROVAR Frequency Converter



Hydrovar is an automatic control device which, when coupled to a frequency variator, controls one or more pumps based on the increase in water demand.

By maintaining constant the system pressure or differential pressure or flow it ensures excellent energy savings as well as optimum performance.



APPLICATIONS

- Fully automatic pressure boosting systems for civil, residential and industrial buildings, with speed regulation.
- Automatic system with speed regulation to compensate for increased friction loss during periods of high water demand.
- Single and twin circulator pumps, with continuous variation of delivery and pressure according to the system's characteristic curve.
- Pumps with automatic speed regulation to ensure constant delivery when pressure variations occur.

THE HYDROVAR TECHNOLOGY

- The HYDROVAR integrated device features automatic regulation of the number of revolutions of an asynchronous three-phase electric motor, by interpreting a passive 4 to 20mA signal.
- HYDROVAR will mount directly onto standard 240/415 V, three-phase TEFC motors with class F insulation up to 22 kW.

- From 30 kW, HYDROVAR is available only in the wall-mounted version (also available, on request, below 15 kW).
- The automatic device is programmed directly by means of two touch keys on the back and a liquid crystal display on the front.
- Three LED's signal "POWER", "RUN" and "FAULT". The device can be programmed in seven languages.

SPECIFICATIONS

- Single phase models:
Hydrovar HV 2/.. Series
Power: 1.5 - 2.2 kW.
Mains voltage: 230 V \pm 15%, 40 to 60 Hz.
Motor voltage: three-phase 230 V, 50 to 60 Hz.
- Three-phase models:
Hydrovar HV 3/.. series
Power: 2.2 to 45 kW.
Mains voltage: 3x400 V \pm 15%, 40 to 60 Hz.
Motor voltage: 3x400 V, 50 to 60 Hz.
- Protected by password.
- Ambient temperature: 5 to 40°C.
- 50% humidity at 40°C and 90% at 20°C.
- IP54 protection.
- Electrical and hydraulic pump protections.
- Incorporated harmonic filter in compliance with EN 55011, to avoid any reactions in the low voltage areas.
- An RS485 interface allows communication with a control station.
- Incorporated fault signal memory log.

GENERAL CHARACTERISTICS

The HYDROVAR frequency converter, by starting or stopping the pumps sequentially according to the rate of consumption, maintains a pre-set value constant. This value may represent the pressure or differential pressure, the flow, water level or temperature, compensating for increased friction loss in the system. HYDROVAR can also be controlled through an external system which supplies a passive 4 to 20mA signal. In this case the user controls the motor speed directly.

HYDROVAR has two regulation modes: the first is called "NORMAL": if the value drops, the rotation frequency is increased.

This regulation mode is used to obtain:

- Constant pressure on the pump's delivery side.
- Constant differential pressure.
- Constant delivery.
- Constant level in a closed or open tank or boiler downstream from the pump.

- The second is called "INVERTED": if the detected value drops the rotation frequency is lowered.

This regulation mode is used to obtain:

- Constant pressure on pump's suction side.
- Constant level in a tank installed upstream from the pump.

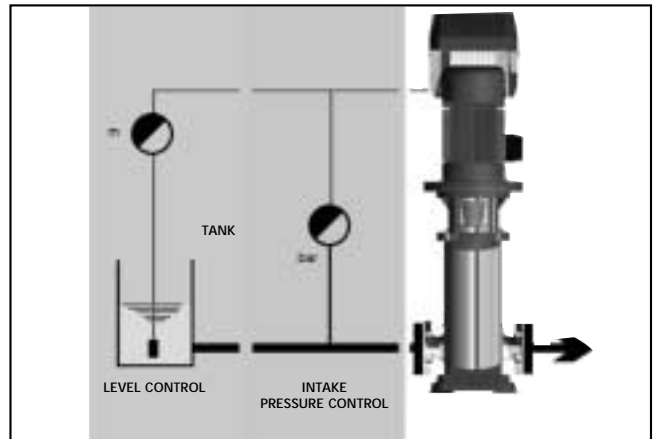
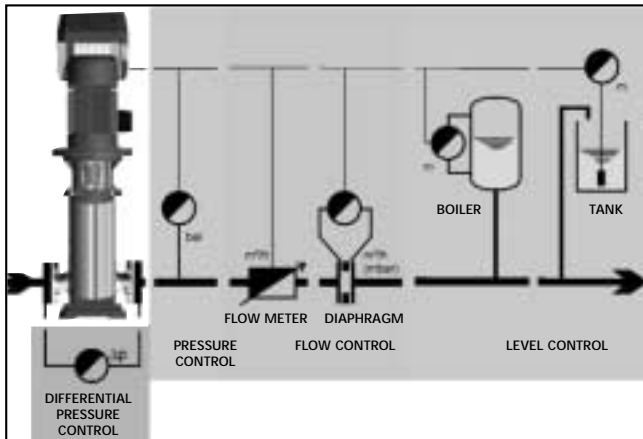

HYDROVAR can be connected by cable to another control system with microprocessor, using the RS-485 data bus located on the main terminal board under the cover.

This enables the HYDROVAR system to send information about the pump and system conditions to an external unit and to be controlled from a distance.

The HYDROVAR protocol is 9600 data bits baud, with no stop or parity. If the external device uses a 24 V interface, an RS 322/RS 485 conversion interface may be necessary.

CONFIGURATIONS

The HYDROVAR control system is currently available with the Lowara SSV, SFH, SFC, SSH and SVI series pumps.

Each of these configurations has been specifically selected to guarantee optimum performance and energy savings, and to meet the requirements of a wide range of systems.

SPECIFICATIONS

HYDROVAR		SUPPLY VOLTAGE (40 TO 60 Hz FREQUENCIES)	MOTOR	
MODEL	RATED POWER kW		VOLTAGE	CURRENT (A)
HV 2.1	1,5	230 V, 1 single-phase +/- 15%	230 V, 3 three-phase	7
HV 2.2	2,2	230 V, 1 single-phase +/- 15%	230 V, 3 three-phase	9
HV 3.2	2,2	400 V, 3 three-phase +/- 15%	400 V, 3 three-phase	5
HV 3.3	3,0	400 V, 3 three-phase +/- 15%	400 V, 3 three-phase	7
HV 3.4	4,0	400 V, 3 three-phase +/- 15%	400 V, 3 three-phase	9
HV 3.5	5,5	400 V, 3 three-phase +/- 15%	400 V, 3 three-phase	12
HV 3.7	7,5	400 V, 3 three-phase +/- 15%	400 V, 3 three-phase	15
HV 3.11	11,0	400 V, 3 three-phase +/- 15%	400 V, 3 three-phase	22
HV 3.15	15,0	400 V, 3 three-phase +/- 15%	400 V, 3 three-phase	29
HV 3.18	18,5	400 V, 3 three-phase +/- 15%	400 V, 3 three-phase	35
HV 3.22	22,0	400 V, 3 three-phase +/- 15%	400 V, 3 three-phase	42
HV 3.30	30,0	400 V, 3 three-phase +/- 15%	400 V, 3 three-phase	60
HV 3.37	37,0	400 V, 3 three-phase +/- 15%	400 V, 3 three-phase	75
HV 3.45	45,0	400 V, 3 three-phase +/- 15%	400 V, 3 three-phase	88

NOTES

A three-phase TEFC motor must always be used with the HYDROVAR converter.

The motor connects to the HYDROVAR and the HYDROVAR connects to the power supply.

The HYDROVAR system comes with a pressure transducer, transducer connection cable and transducer mounting hardware as standard.

The standard pressure transducer is AISI 316L stainless steel with an FPM gasket.

The following versions are also available: pressure transducer with 10 bar full scale, 25 bar for constant pressure applications, differential pressure transducer with 4 bar full scale for variable pressure and delivery applications (characteristic system curves) or constant delivery applications (to be provided with suitable diaphragm).

Moreover, the HYDROVAR system can work with any sensor (level, velocity, temperature, chemical concentration, flow, etc...) emitting a passive 4-20 mA signal.

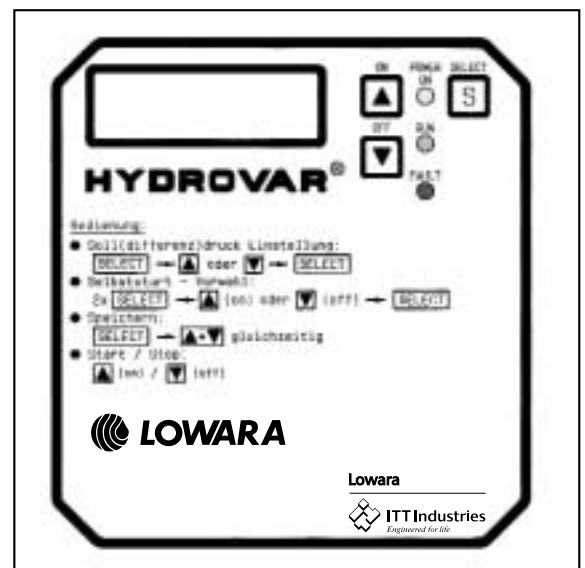

TYPICAL APPLICATIONS

Any application requiring variable hydraulic data; these conditions are normally found in applications involving water supply and circulation.

MARKET	APPLICATIONS
HVAC	Boiler feed Heat exchangers Chillers Induction heating Air filtration Water circulation
Municipal	Pressure booster stations/Water works supply Fountains
Building industry	Pressure boosters for high rise/Irrigation systems
Water purification	Reverse Osmosis systems Filter feed Production of deionised and ultrapure water
Agricultural/Recreational	Irrigation systems Water supply and transfer
OEM	Variable flow and pressure wash systems Fluid circulation with variable flow Booster systems Fountains
Waste water treatment	Sewage pumps & mixers (wall-mounted version) Cleaning systems
Industrial applications	Formulation systems Spray wash systems Seal barrier fluid systems Cooling towers

TYPICAL APPLICATIONS

**HVAC: HEATING, VENTING
& AIR CONDITIONING**

Circulators (single or twin pumps) with continuous flow and pressure variation to follow system curves.

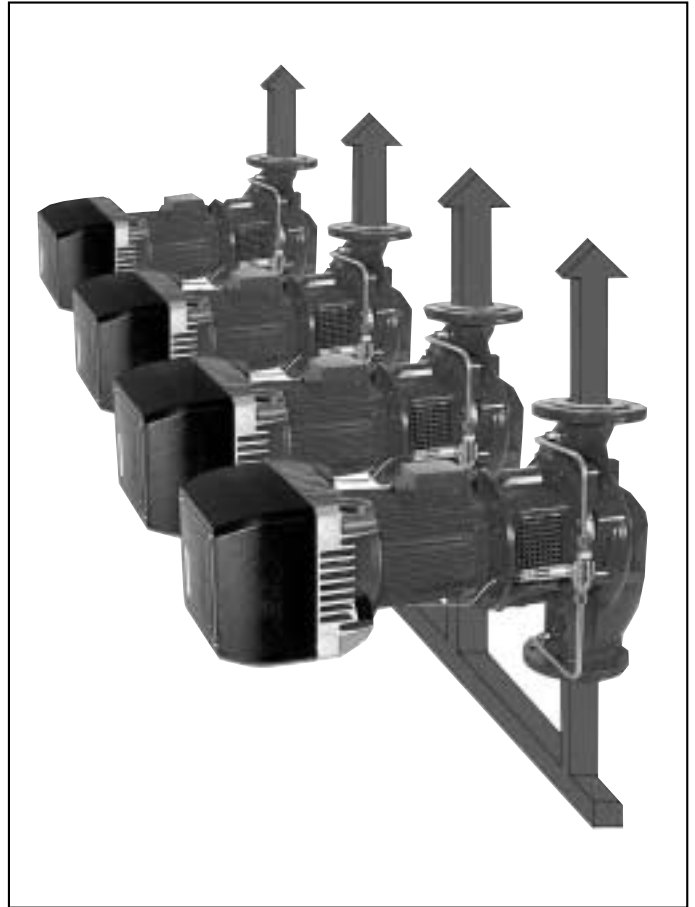

WATER SUPPLY

Booster units comprising up to 4 pumps, with speed regulation to increase pressure in buildings' water systems.

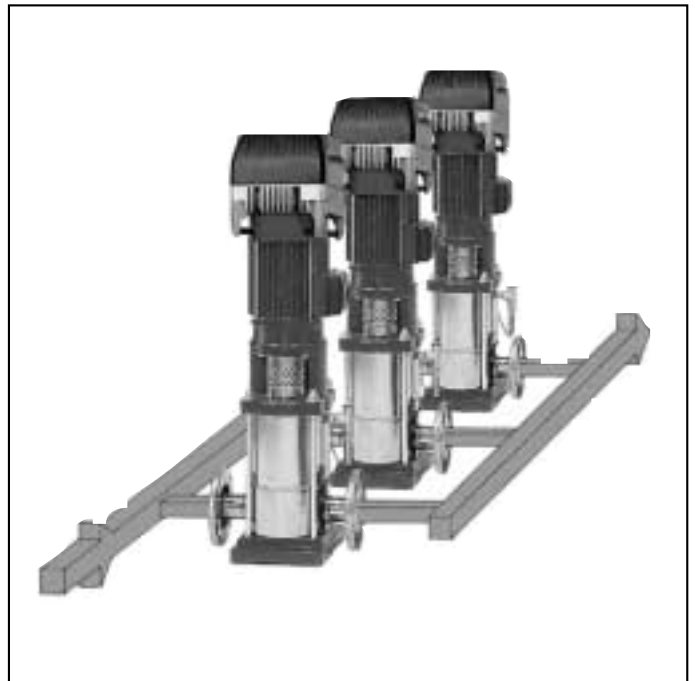

HYDROVAR

WATER TREATMENT AND PROCESSING PLANTS

Automatic speed control system for constant flow at variable pressure.

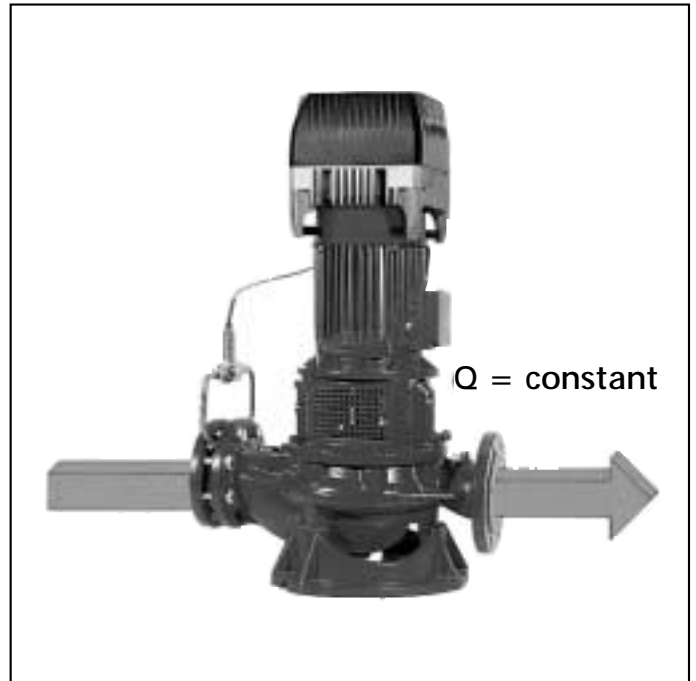

HYDROVAR

WATER SUPPLY

Automatic system with speed control to compensate for increased friction loss during peak consumption periods.

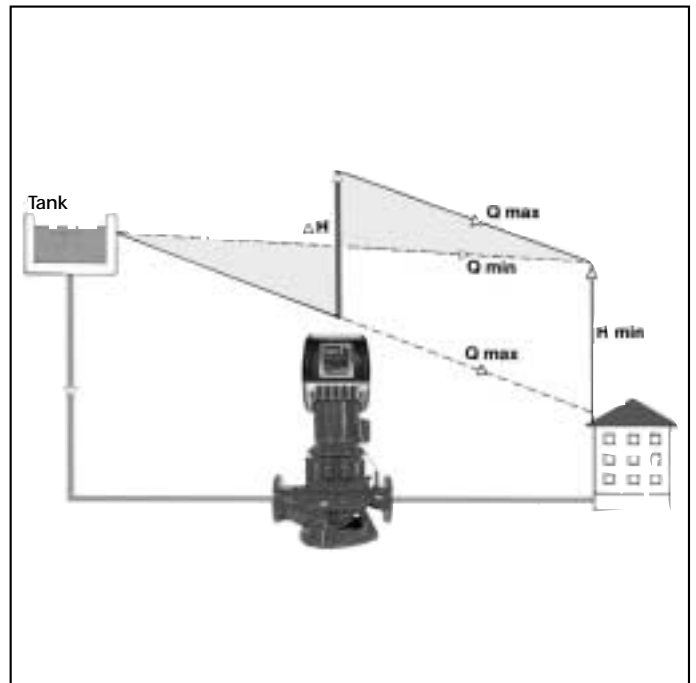

FLAMEPROOF MOTORS

Flameproof motors are often required in processing plants. That's why a wall-mounted version is available.

HYDROVAR

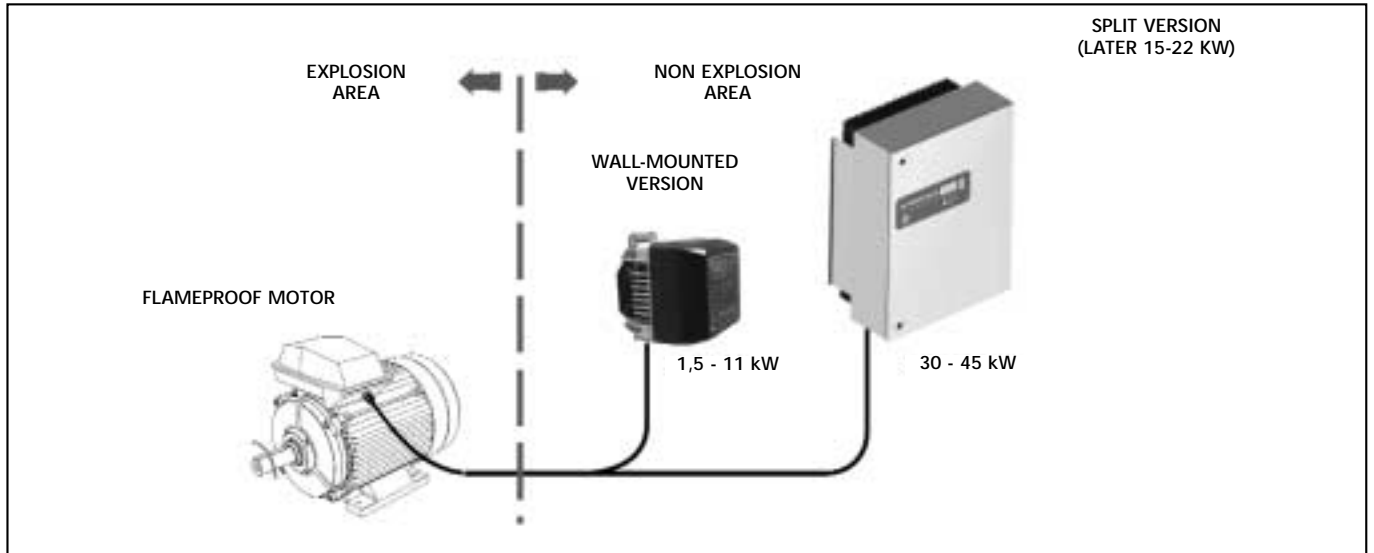

WALL-MOUNTED HYDROVAR COMBINED WITH SUBMERSIBLE PUMPS (DRAINAGE - SEWER)

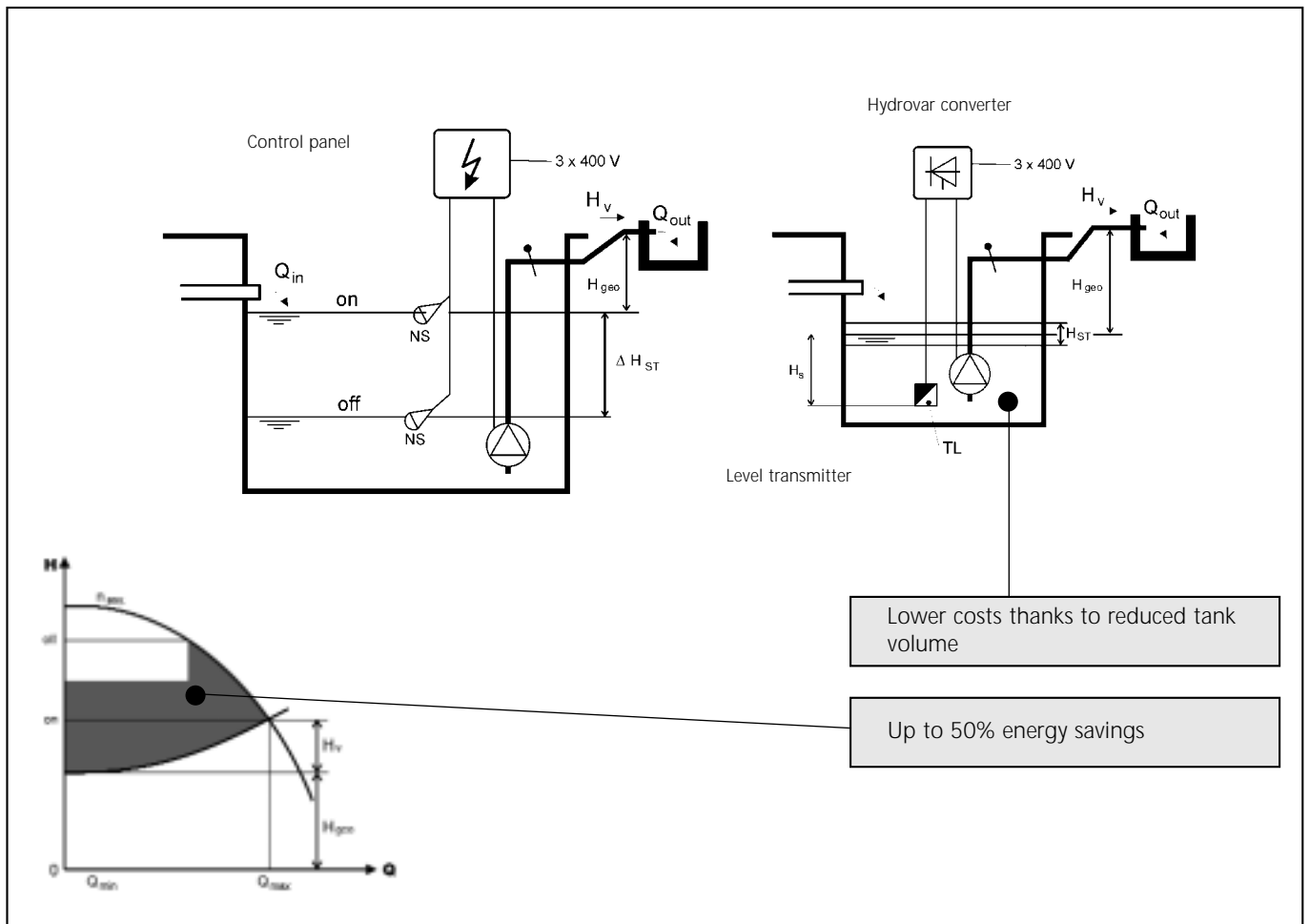

OPERATION

The principal function of the HYDROVAR device is pump regulation to meet system demands.

HYDROVAR performs these functions:

- 1) It measures the system's pressure or delivery through a transducer mounted on the pump's delivery side.
- 2) It calculates the speed of the motor in order to maintain the required delivery or pressure.
- 3) It sends a signal to the pump to start the motor, increase or reduce speed or stop.
- 4) In multiple pump installations, HYDROVAR automatically controls cyclic pump changeover.

In addition to these basic functions, HYDROVAR can do things only by the most advanced computerised control systems can do, such as:

- Stop the pump(s) when demand is zero.
- Stop the pump(s) in case of water failure on the suction side (protection against dry running)
- Stop the pump if the required delivery exceeds the pump's capacity (protection against cavitation caused by excessive demand), or automatically start the next pump in a multiple series.
- Protect the pump and motor from overvoltage, undervoltage, overload and earth fault.
- Vary the pump speed acceleration and deceleration time.
- Compensate for increased friction loss at high flow rates.
- Conduct automatic test starts at set intervals.
- Monitor the converter and motor operating hours.
- Display all functions on an LCD in different languages (Italian, English, French, German, Spanish, Portuguese, Dutch).
- Send a signal to a remote control system which is proportional to the pressure and frequency.
- Communicate with another HYDROVAR or control system via an RS 485 interface.

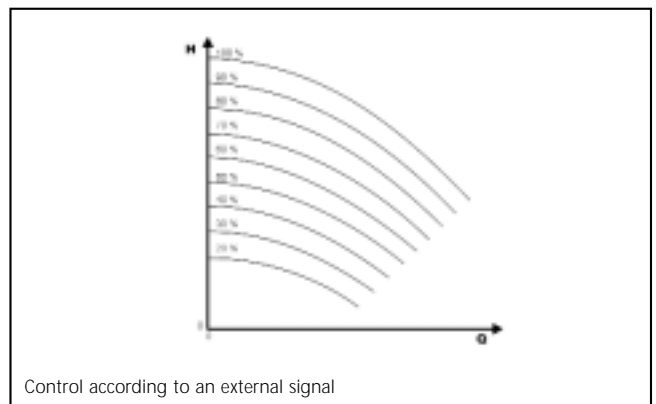
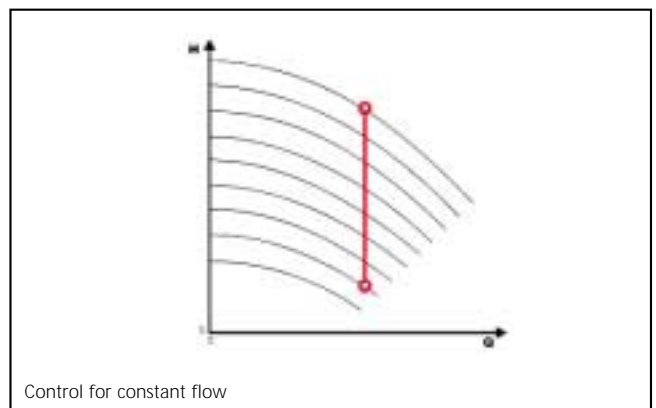
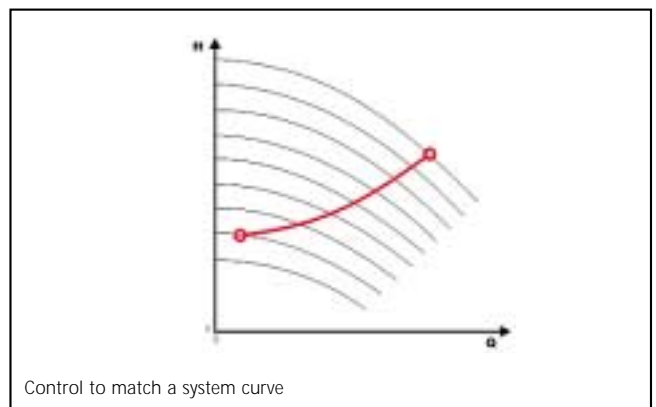
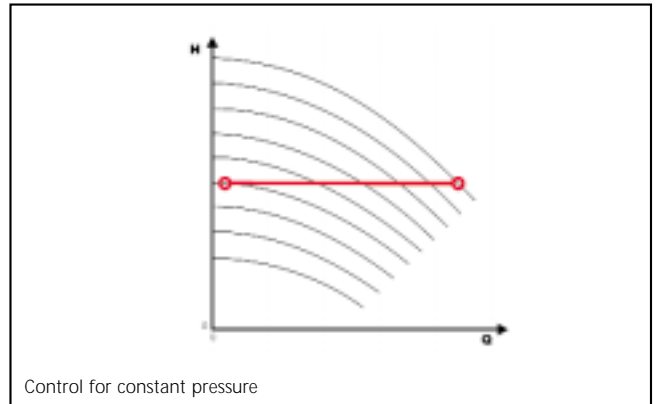

PUMP SELECTION

CONSTANT PRESSURE SYSTEM

When selecting a variable speed pump you need to know two fundamental things: the required pressure and the maximum system capacity.

When you know these values, you must check the performance curves of the variable speed pumps available, and select the pump which covers the nominal pressure up to the maximum capacity. This value should be on the right of the pump's maximum performance point and within 10% of its maximum efficiency.

To limit the electrical input, the selected pump should meet the point of maximum pressure and capacity as near as possible to the curve of the pump's maximum speed.

In a multiple pump system, you may select pumps that supply only part of the maximum capacity required. This will provide an incorporated reserve for most of the delivery range, and will ensure uniform pump wear.

You must also calculate the NPSH based on the point of maximum nominal delivery and pressure. This is the worst case condition, since performances at lower speed require lower NPSH.

CONSTANT DELIVERY SYSTEM

In constant delivery applications, the single pump capable of ensuring the required delivery is usually selected based on the data shown in the figures on the right.

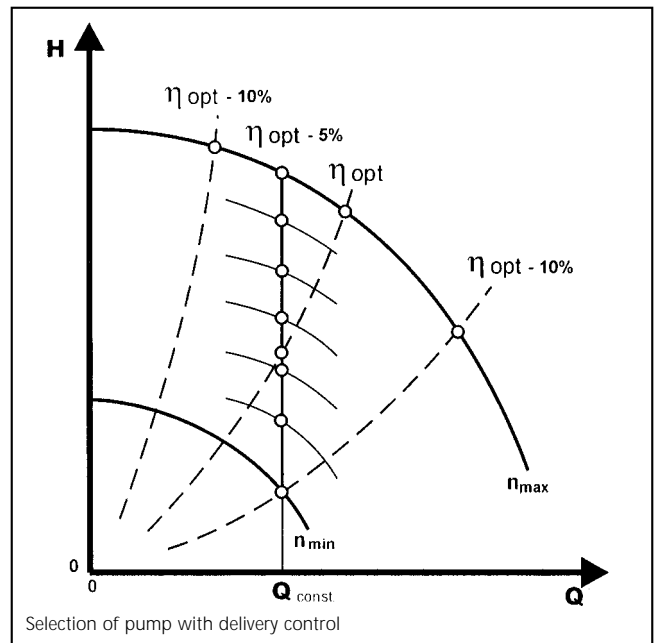
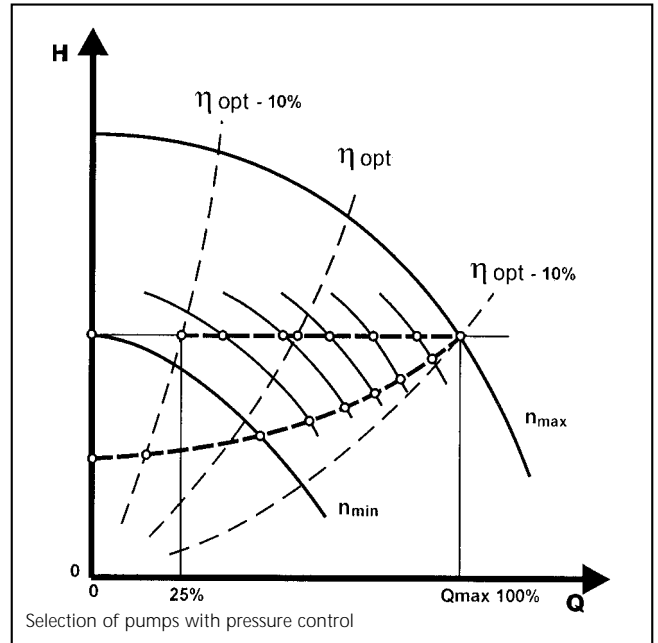

HYDROVAR FOR SINGLE PUMP CONTROL

The HYDROVAR controller can be used on single as well as multiple pump systems.

If there is only one pump the following control modes are available:

1. CONSTANT DELIVERY PRESSURE

With this method the desired delivery pressure is set (in bar) by the operator. The HYDROVAR system varies the pump speed as the demand increases or decreases to keep the pressure constant.

For this application it is necessary to select a pump suited to the system characteristics.

The maximum pressure and flow required by the system must not exceed the performance curve at the pump's maximum speed (usually 2950 rpm).

A single pump should not be selected if it cannot meet the maximum system requirements.

2. COMPENSATION FOR FRICTION LOSS (FOLLOWING SYSTEM CURVE)

The system can increase the delivery pressure of the pump according to flow increases to compensate for the added friction loss in the system.

This allows the pump to follow the system curve. To do this, the operator enters the percentage increase in delivery pressure required at the maximum speed and flow. In addition, the operator selects the speed at which this increased pressure will start.

The pump should be selected so that the maximum flow is on or below the system curve (2950 rpm).

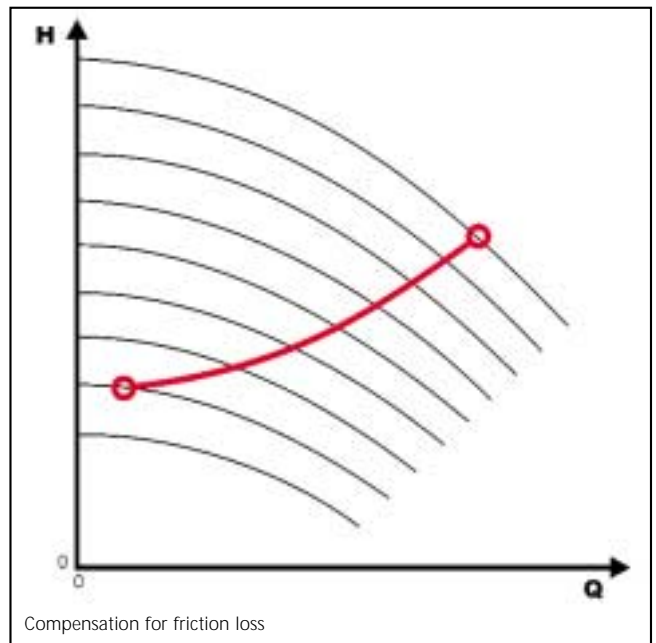
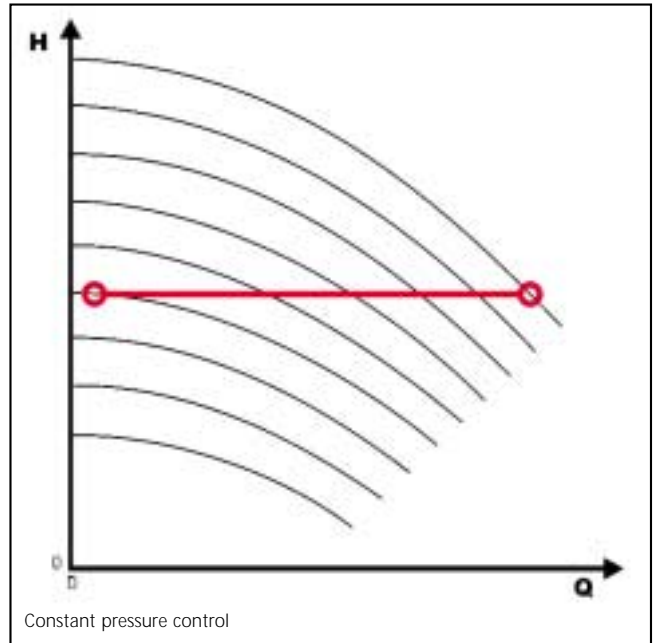

3. CONSTANT FLOW

This method allows the operator to set the required flow in either circulator or process applications.

The actual flow value can be measured either by means of a flow sensor (4-20 mA, linear function activated) or by using an orifice plate in combination with a differential pressure transducer (4-20 mA, quadratic function activated).

The required parameters must be set while programming the unit.

As demand changes the HYDROVAR increases pressure to maintain a constant flow.

The pump should be selected so that the flow required is near the maximum efficiency point of the pump, and the maximum pressure required is within the pump performance range at full speed.

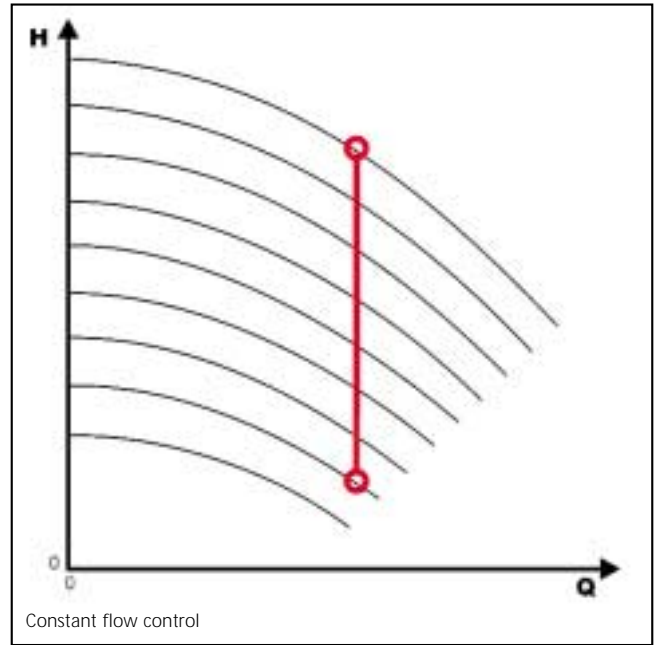

4. ACTUATOR MODE

In actuator mode the pump speed can be varied via an external source using a 4-20 mA signal. In this case no sensor need be installed on the pump.

5. PROTECTION AGAINST DRY RUNNING OR EXCESSIVE WATER DEMAND

If the required value (pressure or flow) cannot be achieved within a predefined period of time, the controller will switch off automatically. If the automatic reset function is enabled, the system will try to restart 5 times, but will switch off completely after five unsuccessful attempts.

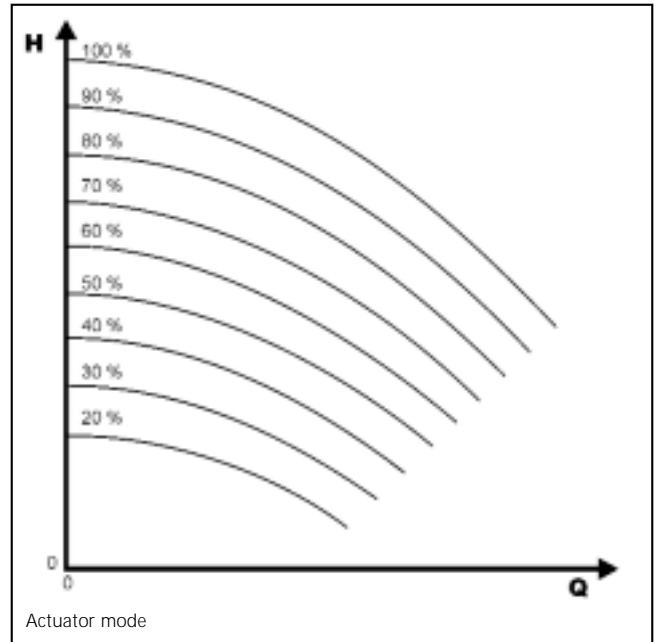

HYDROVAR

HYDROVAR MULTIPLE PUMP CONTROL

HYDROVAR can control up to 4 pumps operating in series.

The microprocessors monitor the activity of each HYDROVAR to adjust the overall system performance. The RS 485 interface enables the exchange of information between units, so that no other control panels are necessary.

CONSTANT PRESSURE SYSTEMS

In a multipump system the HYDROVAR maintains a constant delivery pressure by starting or stopping the pumps sequentially according to the water demand.

SET UP

In a multiple pump system the HYDROVAR units are linked together through the RS 485 interface.

The operator sets each HYDROVAR to "sequential mode" and assigns an address to each pump (Addr. 1, Addr. 2, etc.).

Next, the operator enters the required system pressure and the pressure drop allowed before the next pump starts.

AUTOMATIC STARTING SEQUENCE INVERSION

The HYDROVAR will automatically change the pumps' starting sequence so as to ensure uniform wear.

Since the changeover is based on the pump's operating time, the operator can set a value ranging from 1 to 100 hours.

COMPENSATION FOR SYSTEM FRICTION LOSS AS THE FLOW INCREASES

Increased flow results in increased friction loss. The constant pressure setting can be modified through the automatic activation of a function that slightly increases the set pressure value every time an additional pump is started.

